

THE ELECTRICAL EXPERIMENTER.



TRADE
ELECTROSE
MARK.

REG. U.S. PAT. OFF. & FOREIGN COUNTRIES.
INSULATION.



1000 TO 1000000 VOLTS

LOUIS STEINBERGER'S PATENTS

Adopted by **U. S. NAVY**

and all the Commercial Wireless
Telegraph Companies

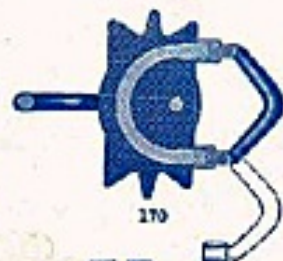
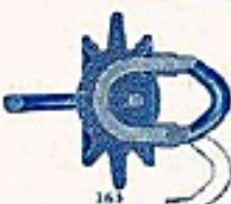

ELECTROSE MFG. CO.,

60-72 Washington St.
66-76 Front St.

**BROOKLYN, N. Y.
AMERICA**

THE BEST Evening Course in Wireless in New York

If you live nearby and wish to hold your present position, while studying at night. Complete equipment—twelve instructors. Prepare for a government license—become a Licensed Engineer.

Day Courses in Operating and Construction
Evening Courses in Engineering, Operating and Drafting. Spanish for Operators.
New Class in Engineering starts soon.

Y. M. C. A. TELEGRAPH SCHOOL

145 East 86th Street, NEW YORK

Everybody Needs **The BEERS Lantern**
GIVES LONG SERVICE AT VERY LOW COST
Burns from **40 to 60 Hours**



Made to use a common dry cell battery which can be bought anywhere for 25 cents. Not a toy but a reliable, practical, electric lantern, sure to displace the old unsafe oil lanterns and uncertain flashlights.

Durable, handsome, compact, absolutely safe. A sensible, economical article for every day use. Indispensable for housekeepers, automobilists, farmers, sportsmen, yachtmen, watchmen, deliverymen, etc.

Permanent and intermittent contact switch. Tantalum lamp. Imported optical lens. Silver plated reflector.

Doctors write quick for sample and further information

Prices delivered anywhere in the United States
No. 1905 Pressed Steel, black rubber finish, \$2.39
No. 1909 Solid Brass, highly polished, 2.58
No. 1902 Solid Brass, nickel plated, 2.39

THE BEERS SALES COMPANY
1008 E BROAD STREET BRIDGEPORT, CONN.

CRYSTALOI

The New Permanent Wireless Detector

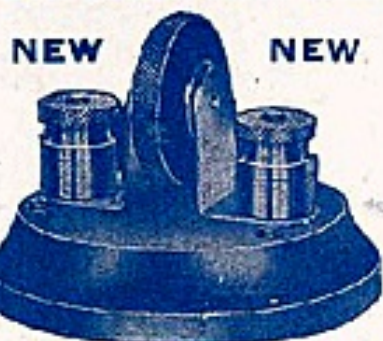

EXTREME LONG DISTANCE

MICROMETRIC ADJUSTMENT

This WONDERFUL LITTLE DETECTOR is the height of Mechanical and Electrical achievement and will simply astonish you in its performance. IT WILL NOT BURN OUT OR GO DEAD and will last indefinitely. All elements are sealed in the little cylinder which is revolved to secure finest adjustment. The "CrystalOI" is positively the most sensitive and thoroughly practical detector ever designed. It is not a make-shift. It is a precision instrument in every sense of the word, and is beautifully finished. EACH "CRYSTALOI" is tested for extreme long distance at our station, which insures the one you get being absolutely perfect or money refunded. WRITE TO-DAY for full information. Immediate delivery.

Price \$3.50, including postage

WIRELESS DIVISION
EUGENE T. TURNEY CO.
2905-B THIRD AVE., NEW YORK CITY

- THE - ELECTRICAL EXPERIMENTER

Vol. II.

APRIL, 1915

NUMBER 12

100,000 Cycle Alternators

THE advent of radio-telegraphy probably developed no more interesting electrical machine than the 100,000 cycle per second alternator here illustrated. This wonderful machine was built by the General Electric Company, and we present these views through its courtesy. Two of these high frequency generators are shown in our photo, each being coupled to a driving motor through a reduction gearing. The

used for wireless telephone work the A. C. radio-frequency generator is commonly connected in series with the antenna and a suitable microphone transmitter to control the radiated energy by the voice waves.

At the enormous speeds at which such machines operate the bearings are supplied with oil under pressure; a pump insuring a steady flow of oil through the grooves therein. A section of shaft and journal is seen in the photograph.

THE ELECTROTONE.

The present illustration and drawing shows the construction of the Electrotone, a Medical Electric-Current Regulator, designed at Murray, Utah, and consisting of an insulated glass tube con-

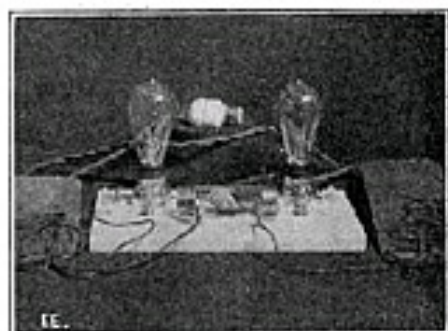

taining a moistened sponge acting as a resistance element, which is introduced into the circuit to modify its intensity.

When the poles connecting with the sponge are brought closer together, making better contact with and compressing the sponge, the resistance of the moist sponge is less and the current is diminished and finally the contact with the sponge and the current are broken. It is stated by Dr. A. J. Hoens, the designer of this apparatus, that the advantage of this arrangement is that a current can be very gradually turned on or off without appreciable make or break, and can be smoothly varied or undulated during treatment of a patient so as to give alternate contractions of muscles. This instrument is said to give a true Electrotonic current, which has been found superior in many respects to any other cur-

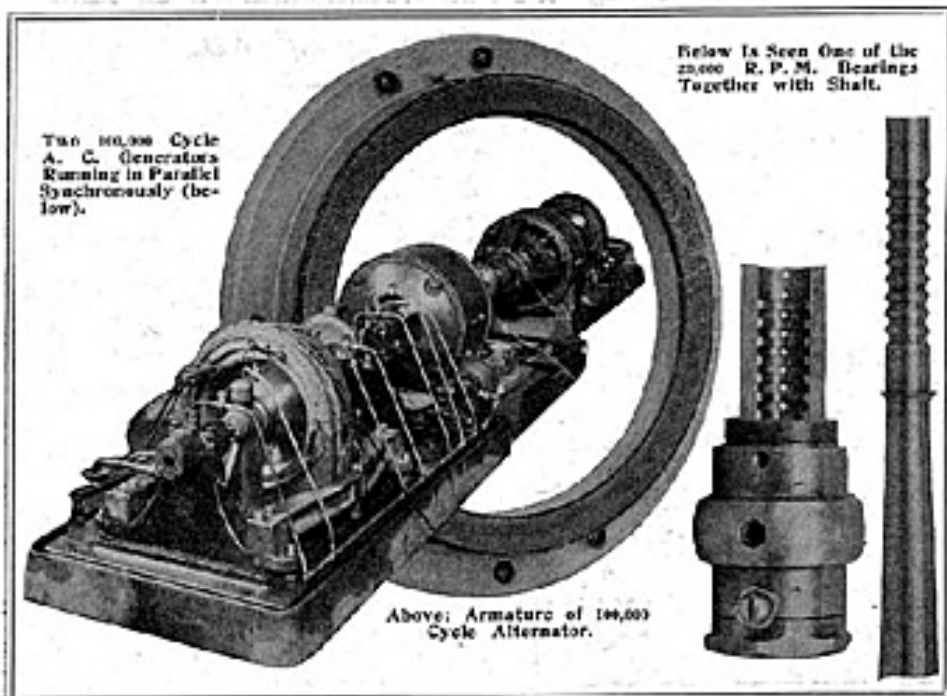

two complete sets are here illustrated operating in synchronism, the same as in regular power work where A. C. generators are synchronized. It is a nice bit of work to build two machines like these which can be speeded up to 20,000 R. P. M. and controlled as desired.

These radio-frequency alternators are built to develop as high as 200,000 cycles frequency per second, such as that installed in the radio laboratory at Columbia University and described in the December, 1914, issue of this journal.

The generators here shown are rated at 2 K. V. A. or 2 K. W. (2,000 watts) at 100% power factor. They usually are wound to produce about 100 volts and a corresponding current in amperes. When

rent for the relief of pain, for strengthening the nerves and muscles, and improving the activity of the organs and tissues of the body. It is used in connection with the ordinary 110 volt, alternating electric light current, and one lamp is introduced in series, the current then being connected to the regulator. A Faradic current, generated by dry cells, can be used where no electric light current exists, and regulated

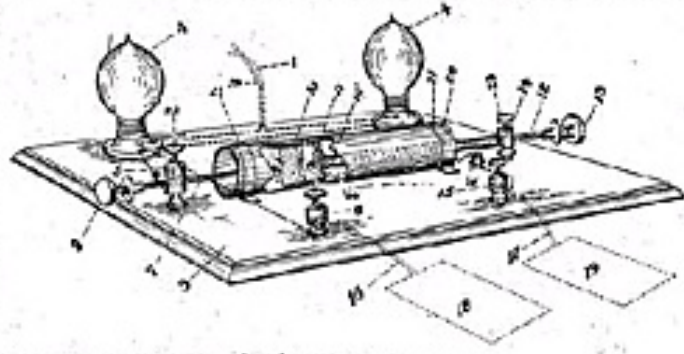

in the same manner.

FRANK C. PERKINS.

"The Electrical Experimenter" is published on the 15th of each month at 233 Fulton Street, New York. There are 12 numbers per year. The subscription price is 50 cents a year in U. S. and possessions, Canada and foreign countries 75 cents a year. U. S. coin as well as U. S. stamps accepted (no foreign coin or stamps). Single copies 10 cents each. A casual copy will be sent gratis on request. Checks and money orders should be drawn to order of the Experimenter Publishing Co., Inc.

If you change your address notify us promptly, in order that copies are not misrouted or lost.

All communications and contributions to this journal must be addressed to: Editor, "The Electrical Experimenter," 233 Fulton Street, New York. We cannot return unaccepted contributions unless full return postage has been included. ALL accepted contributions are paid for on publication. A special rate is paid for novel experiments; good photographs accompanying them are highly desirable.

Entered as second-class matter at the New York Post Office, March 1, 1915, under Act of Congress of March 3, 1879. This registered U. S. Patent Office. Copyright, 1915 by E. P. Co., Inc., New York. The Electrical Experimenter, Monthly. Published by the Experimenter Publishing Co., Inc., 233 Fulton Street, New York.

ELECTRIC SIGNS IN SINGAPORE.

Although the electric sign has completely vanished from the night sky of London for the time being, sign business is still to be obtained from places where a reduction in lighting is not necessary, both at home and abroad. Siemens Bros.

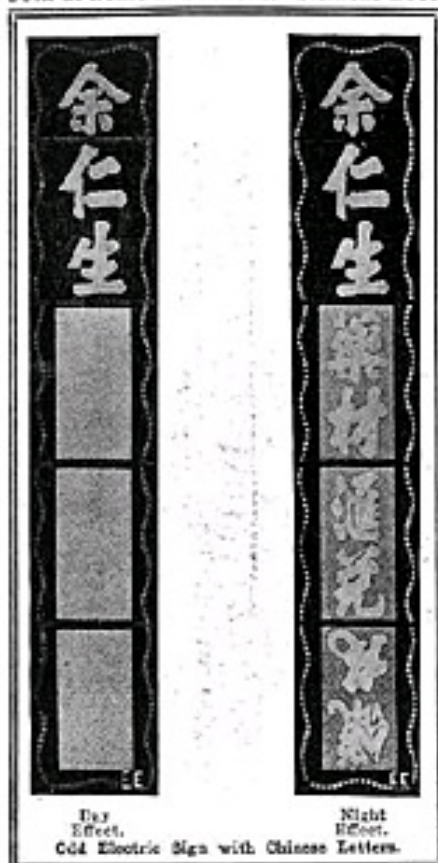

Dynamo Works (Ltd.) have recently completed a novel sign which was ordered through their Singapore branch. This sign affords an excellent example of methods which are in vogue in the Straits Settlements. We reproduce two illustrations showing respectively the day and night appearance of this novel sign. The sign is 14 ft. long by 2 ft. 3 in. wide by 1 ft. deep, and is to be fixed from the roof of a very lofty store. The local regulations prohibit the fixing of a sign which projects more than 3 ft. deep, and it was, therefore, necessary to arrange the advertising matter on the sign to read vertically. The Chinese characters lend themselves to this style of design, and the top three which are visible day and night represent the name of the store. This lettering changes in colour red, yellow and green in succession when illuminated at night time, with a complete blanking out in between the different colours. Each of the remaining panels advertise some article manufactured by the store, and they figure on the sign in rotation in the same colour as the name of the firm appears, so that with each change of colour in the name there is a change of advertisement on the sign itself. These lower panels appear absolutely blank in the day time. The wavy beaded border is arranged on the chasing flasher plan, two sections of 12 beads, that is, two lengths of approximately 18 in. are blocked out mechanically in succession all round the border. In order to obtain the results described about 30 distinct lamp circuits had to be wired and the number of Tungsten lamps employed is about 150. These have

AN ELECTRIC FROST ALARM.

By Frank C. Perkins.

THE illustration herewith shows a most interesting electric equipment as developed at Rochester, N. Y. Some sections of an orange, lemon or grape fruit orchard have a decided drop in temperature while other sections better protected or on different level are not affected. A sudden fall in temperature usually occurs during the night. Frost fighting, at best, is not a pleasant job, but to maintain a force of men to meet the emergency, to have them rush out into the cold dark night, filling and lighting smudge pots, making a tremendous effort at great physical and cash expense to find that it has been in vain because of faulty or unreliable information; this is an experience to try men's souls.

With this electric indicating device installed, it is no longer necessary to detail a man at night to watch thermometers located in different sections of the orchard, nor is it necessary to set the alarm clock to awaken the rancher at intervals through the night to consult his thermometer against any sudden raid of Jack Frost.

The owner of the orchard may retire at night with a feeling of security that the automatic alarm thermometer is on guard over the interest of the owner's orchard and that he will be warned at the first approach of danger.

This electric automatic alarm thermo-

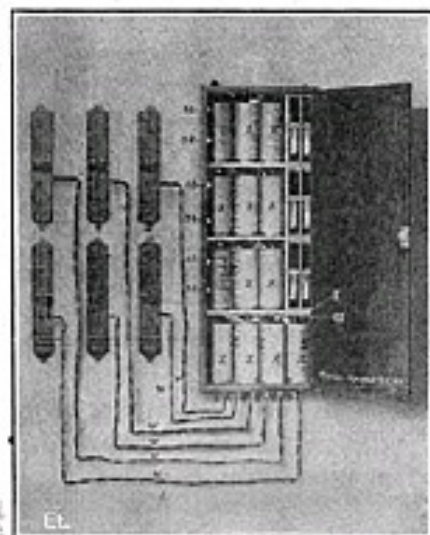

meter is a specially made instrument with a fine platinum wire fused into the bore of the tube connecting with the mercury column at 32° F. or any other permanent point desired. A second wire touching the mercury at a point below the other, completes a circuit which is broken the instant the mercury drops be-

been varnished by the Siemens process to withstand the weather. The flasher is of the motor driven pattern and controls the main panel circuits and the border at the same time. The sign is double sided, each panel being identical. The sign is of strong design, finished with black stove enamel outside and white stove enamel inside.

EARLY TYPES OF DYNAMOS.

We of this age are prone to forget the early stages of electric lighting, when the largest dynamos for lighting lamps were built with difficulty and rated only at a hundred horsepower or so. Especially when we visit such large power houses as those maintained in New York, Chicago, etc., where mighty turbo-alternators revolve at marvelous velocities, and developing the power equivalent to 30,000 horses in a single compact unit. And moreover such units, of the vertical or horizontal type, are so wonderfully

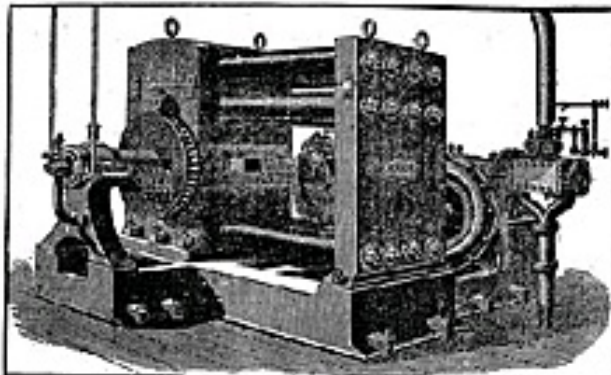

One of First Dynamos.

designed that they occupy little more space than one of the first Edison lighting dynamos, as our illustration shows. This massive looking electric generator was a marvel in its day, but it could only light 1,300 lamps. At full load it developed about 900 amperes at a pressure of 105 volts. It realized an electrical efficiency of 90 per cent., which was very good, all things considered. The engine driving it was rated at about 120 horse power and direct connected. The present turbo-alternators reach as high as 97 and 98 per cent. or more electrical efficiency. The early type of Edison machine here shown resembles those installed in the old Pearl Street station, New York City, many years ago. Like all new inventions, the electric light was at first considered a laboratory freak; many writers of the period having pointed ridicule at it. Edison and his associates of those pioneer days have lived, however, to see the "electric light in a bottle," as it was often termed, supplant other forms of illumination almost to extinction, thru-out the civilized world.

low the designated danger point; the permanent point referred to above.

There is a non-sparking, special relay battery attachment which causes a bell to ring at practically any distance from the thermometer itself, the moment the circuit is broken. Until the alarm rings the danger is not imminent, and all unnecessary expense may thus be spared.

This electric automatic alarm thermometer has been arranged for both the single and the annunciator systems. The first comprises but one single thermometer—the annunciator system operates from 2 to 6 thermometers which may be located in different parts of the orchard all indicating on one annunciator. With this latter system the thermometers may be located, say, three on high point of the orchard and three in the lower lands. The first alarm may come from one of the higher points of the orchard, indicating the need of immediate attention there, while the danger is not so pressing in the low lands.

By observation the orchardist is able to determine almost exactly the coldest

(Continued on page 224.)

100,000 Volt Direct Current X-Ray Machines

THE X-Ray machine of today is a highly perfected device indeed, and in the better class of apparatus on the market adapted to instantaneous X-Ray photographs for hospital and physician's use, the X-Ray tube is supplied with a unidirectional or

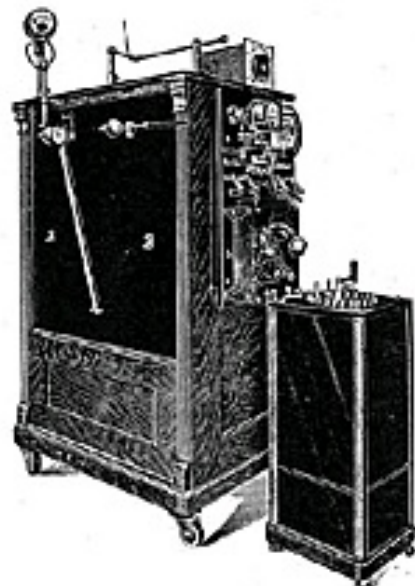

Fig. 1A. Appearance of Modern 100,000 Volt X-Ray Generator Delivering Direct Current.

direct current of anywhere up to 100,000 volts potential and more. The energy used is sometimes as high as 25 K. V. A., which is a large amount to handle, in the way the *interrupterless* X-Ray machines do, and the apparatus for the production of this direct current as built by the Wappler Concern, of New York, is illustrated in the first cut here shown.

The general principle of these unipulsating machines lays in the employment of a high potential step-up closed core A. C. transformer and the high voltage alternating current from the secondary of same is passed thru a commutating device that rectifies the A. C. at, say 100,000 volts, or more, into Direct Current at a corresponding potential.

It is indeed remarkable to note that the transformers used for this work are invariably of the dry or wax impregnated type, altho oil immersed types are utilized by some manufacturers.

It must be understood that this machine, the combination of a transformer, etc., is applicable to an alternating current supply only, but if the direct cur-

rently converter changes the direct current into an alternating. The low potential alternating current collected from the converter side is passed thru the primary of the transformer, which transforms its potential to about 100,000 volts, at a primary current of from 25 to 50 amperes, depending upon the voltage used. The High Potential alternating current is then conducted from the transformer to a rotary polechanger, mounted on the shaft of the converter.

The rotary polechanger consists of a round micanite disc. To the periphery of this disc are fastened two copper strips, opposite each other, and occupying a little more than a quarter of the circumference. Parallel to this disc is a glass plate, on which are mounted four contact plates and brushes equidistantly apart. They are arranged to commutate the current and rectify the High-Tension alternating current to a *high-tension unidirectional* current. The alternating current enters, so to speak, at two opposite contacts, and the rectified current is taken from the two remaining contacts and conducted to the outlet terminals.

The outside mounting and finish of the A. C. apparatus is similar in every

However, it cannot be used for radiographic work, as the wave must be of a pulsating nature, totally, on the one side of the zero potential line to make the current unidirectional. To obtain this characteristic a mechanical recti-

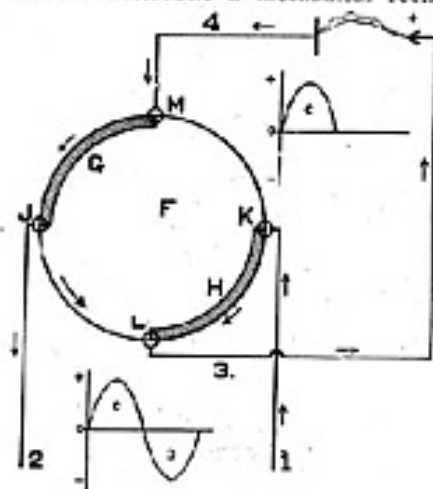

FIG. 3.

fying device is needed. It will be noted at Fig. 2 how the wave "C" appears. On its downward slope it intersects with the zero line. At this point it is necessary to reverse the electrical conductive paths so as to take the next wave or alternation and transpose it to position "E," making it unidirectional.

The figures 3 and 4 give a diagrammatic idea of the rectifying device. "F" is the mica disc, "G" and "H" are two copper commutator strips fastened to the periphery of the disc, opposite each other and occupying a little more space than a quadrant. "J" and "K" are High-Tension Alternating Current brushes. "L" and "M" are the brushes which receive the rectified current. For one complete cycle, or two alternations, the disc makes half a revolution. Fig. 3, wave form "C" shows the first alternation during this period; the disc has made a quarter of a

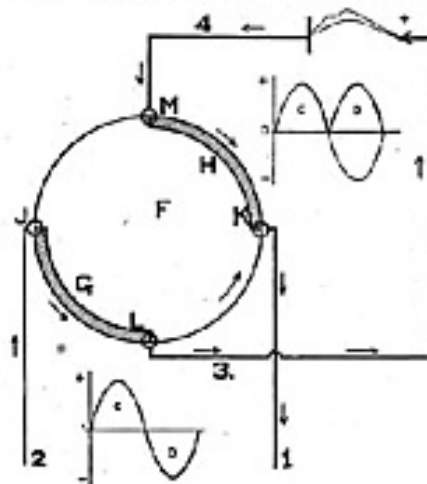

FIG. 4.

respect to the Direct-Current machine. The transformer is connected directly with the incoming street mains, thru the necessary rheostats, switches, etc. A self-starting motor set, connected directly with the supply mains and operating with absolute synchronism with the line circuit, governs the rectifying device. The small size and noiseless operation of this set is a special feature of this apparatus. When using the High-Frequency currents in treatment work, the synchronous motor set is not operated, current being taken direct from the transformer, removing any possible wear or heating from long-extended use.

We may now explain the mechanism of the transformer for rectifying the High-Tension alternating current. Fig. 1 shows the elementary principle of the closed-circuit transformer. "A" is the primary coil, "B" the secondary or high-tension side. This secondary is designed to give a sufficient voltage to jump across an 8 or 10-inch gap.

The character of an alternating current has a wave form, as shown in Fig. 2, the shaded areas "C-D" giving a complete cycle. The wave form of the secondary discharge is also the same.

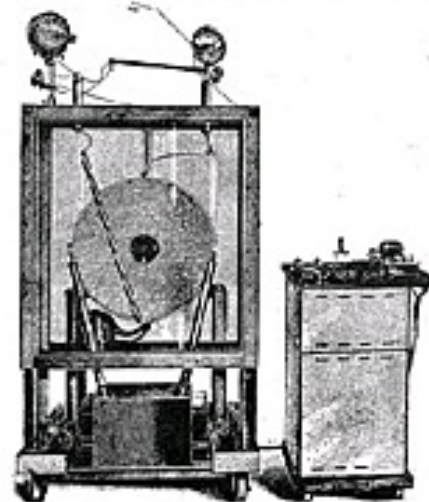

Fig. 5. Heavy Current Interrupterless X-Ray Generator. Micanite Disc is Seen Enclosed in Glass Cabinet, 100,000 Volt Transformer at Base.

revolution and attained the position shown. Fig. 3, Nos. 1 and 2, are the alternating High-Tension current leads to "J" and "K."

(Continued on Page 223.)

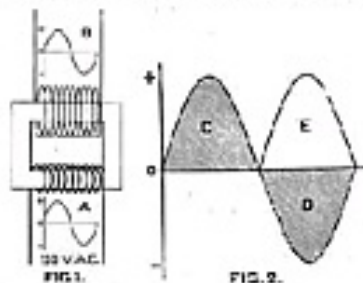

FIG. 1.

FIG. 2.

rent is the source of supply, then a rotary converter is used to produce an alternating current from the direct current. The motor unit consists of a rotary converter on the direct-lighting circuit, either 110 volts or 220 volts. The

Experimental Electricity Course

S. Gernsback and H. Winfield Secor

LESSON 19. PRACTICAL MATHEMATICS.

(Continued.)

The extraction of the cube root is somewhat similar only divisors having larger numbers are employed.

Some of the applications of square root are shown below: Considering the right angled triangle in Fig. 1, if any two of the three sides, a , b and c , are given, then the value of the third side may be calculated. The slanting side c , called the hypotenuse, is equal to the square root of the sum of the base squared plus the altitude squared, or $c = \sqrt{a^2 + b^2}$.

Also
and again

$$a = \sqrt{c^2 - b^2};$$

$$b = \sqrt{c^2 - a^2}.$$

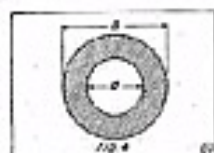

If a perfect square is to have a certain area, then the length of the side of the square is found by extracting the square root of the area. For instance, if a square block of wood was to have 144 square inches area, the length of the side of an equal square having this area, would be $\sqrt{144}$ or 12 inches.

The following notation is used for the formulas given here for finding the various functions of plane figures:

D = Large diameter.

d = Small diameter.

R = Radius corresponding to D .

r = Radius corresponding to d .

p = Perimeter, or circumference.

S = Area of entire surface of solid figure.

A = Area of plane figure.

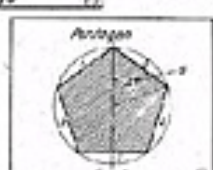
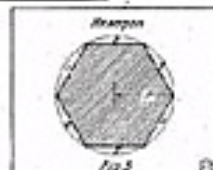

$$\pi = 3.141592 = \text{etc.}$$

V = Volume of solid.

The various functions of the circle are found as follows:

$$\text{Circumference or } p \left\{ \begin{array}{l} p = \pi d = 3.1416 \times d. \\ p = 2 \pi r = 6.2832 \times r. \\ p = 2 \sqrt{\pi a} = 3.5449 \sqrt{a}. \\ p = \frac{2a}{r} = \frac{4 \times a}{d}. \end{array} \right.$$

$$\text{Diameter or } d \left\{ \begin{array}{l} d = \frac{p}{\pi} = \frac{p}{3.1416} = .3183 \times p. \\ d = 2 \sqrt{\frac{a}{\pi}} = 1.1281 \sqrt{a} = \sqrt{\frac{a}{.7854}}. \end{array} \right.$$

$$\text{Radius or } r \left\{ \begin{array}{l} r = \frac{p}{2\pi} = \frac{p}{6.2832} = .1592 \times p. \\ r = \sqrt{\frac{a}{\pi}} = .5612 \sqrt{a}. \end{array} \right.$$

$$\text{Area or } a \left\{ \begin{array}{l} a = \frac{\pi d^2}{4} = .7854 \times d^2. \\ a = \pi r^2 = 3.1416 r^2. \\ a = \frac{p r}{2} = \frac{p d}{4}. \end{array} \right.$$

The area of a circle varies as the square of the diameter, in other words, a 4" circle has 4 times the area of a 2" circle, etc. The circle has the greatest area for a given circumference or perimeter of any figure.

The area of any triangle, such as shown at Fig. 2, is given by the expression:

$$A = \frac{b h}{2} = \frac{1}{2} b h.$$

also

$$A = \frac{b}{2} \sqrt{a^2 - \left(\frac{a^2 + b^2 - c^2}{2b}\right)^2}.$$

The approximate area of an ellipse, such as shown in Fig. 3, is ascertained by the formula:

$$A = \frac{\pi}{4} D d = .7854 D d;$$

The approximate perimeter or $p = \pi \sqrt{\frac{D^2 + d^2}{2} - \frac{(D-d)^2}{8.8}}$.

The area of a flat ring, as seen at Fig. 4, is given by the following rule:

$$A = \frac{\pi}{4} \times (D^2 - d^2).$$

The volume of a sphere is given by the expression:

$$V = \frac{4}{3} \pi r^3 = .5236 d^3.$$

The surface of a sphere, or S , is found thus:

$$S = \pi d^2 = 4 \pi r^2, \text{ or } 12.5664 r^2.$$

Circles, triangles, etc., are divided up by angles, and these angles again sub-divided by degrees, minutes and seconds.

Sixty seconds make one minute, sixty minutes one degree, 90 degrees one right-angle or quadrangle, and 360 degrees a complete circumference of a circle. Protractors or semi-circles of brass and celluloid are usually employed for drawing, their edge being finely graduated in degrees, etc.

If the dividers are set equal to the radius of a circle, Fig. 5, r , then the dividers can be stepped exactly six times around the perimeter, or forming a six-sided figure called a hexagon. A five-sided figure, or pentagon, is shown at Fig. 6. Any sided polygon or figure can readily be laid out by the aid of the following data:

TABLE OF POLYGONAL ANGLES.

Number of sides.	Angle at center. Degrees.	Number of sides.	Angle at center. Degrees.	Number of sides.	Angle at center. Degrees.
3	120	9	40	15	24
4	90	10	36	16	22½
5	72	11	32.73	17	21.3-17
6	60	12	30	18	20
7	51.3-7	13	27.7-13	19	19
8	45	14	25.7-7	20	18

The angle at the center refers to the angle at a , Fig. 6. By means of a protractor graduated in degrees, it is easy to lay out a polygon having any number of sides, by referring to the above table.

For electrical circuits there are a number of different formulas applying for various functions, the basic one for direct current circuits being Ohm's Law. In expressing it the following notation is generally utilized: E = volts or electro-motive force, I or C = current in amperes, R = resistance in ohms.

Then: $E = R \times I$;

$$I = \frac{E}{R};$$

$$\text{and } R = \frac{E}{I}$$

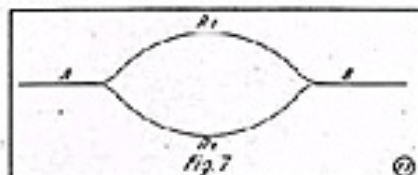

Thus having any two quantities, the third one can be easily found. The watts in a circuit are given by multiplying the volts by the amperes; also,

$$\text{Watts} = E I = C R = \frac{E^2}{R}$$

The horsepower is found by dividing the total watts by 746, and the kilowatts is ascertained by dividing the total watts by 1,000. The coulombs of electricity in a circuit is found by multiplying the current in amperes by the time of its duration in seconds, the coulomb being a current of 1 ampere passing for one second. The work performed in an electrical circuit in Joules equals the product of the volts by the amperes by the time in seconds. The joule is equivalent to 1 watt or 1 volt-ampere for 1 second.

The heat produced in electrical circuits may be calculated as follows: The heat in calories equals:

$$\text{Heat in calories} = I^2 \times R \times T \times .24.$$

T being the time in seconds. The heat produced in British thermal units (B. T. U.) is:

$$\text{Heat in B. T. U.} = I^2 \times .24 \times R \times T \times .0033.$$

The volts lost in a circuit equals the product of the current by the resistance. The resistance of a copper wire increases 21-100ths, of one per cent. for each degree rise in temperature Fah., or the degree Fah. constant for copper wire is .0021.

The joint resistance of a divided or split circuit, such as that appearing at Fig. 7, is found as described below. If the circuit has two branches, such as R_1 and R_2 , then the joint resistance of the two branches, from A to B , is:

$$\text{Joint } R = \frac{R_1 \times R_2}{R_1 + R_2}$$

For a number of like resistances connected on multiple the joint resistance is:

$$\text{Joint } R = \frac{R_1}{\text{number on multiple}}$$

The joint resistance of several different resistances connected on multiple is found by taking the reciprocal of the sum of the reciprocals of the separate resistances, or conductances. The conductance of a circuit in ohms, being the reciprocal of the resistance

$$\text{or } \frac{1}{R}$$

The joint resistance of three branched circuits connected on multiple, as in Fig. 7, is completed from the above rule as follows:

$$\text{Joint } R = \frac{1}{\frac{1}{R_1} + \frac{1}{R_2} + \frac{1}{R_3}} = \frac{1}{\frac{1}{R_1}}$$

And the reciprocal of this is $\frac{1}{R_1}$, or the joint resistance. For

example, let the three resistances have assigned values of 4, 5 and 2 ohms, respectively, then:

$$\text{Joint } R = \frac{1}{\frac{1}{4} + \frac{1}{5} + \frac{1}{2}} = \frac{19}{20}$$

and the reciprocal is:

$$\frac{20}{19} \text{ or } 1\frac{1}{19} \text{ ohms.}$$

The capacity of electrical condensers is approximately computed by the equation:

$$C = \left(\frac{2.248 \times K \times a}{t \times 10^{12}} \right) - 10^6$$

Where: C is the capacity in farads. K is the inductivity of the dielectric, taken from table in any text book. a is the active area of dielectric or insulation, coated on both sides with charging foil, expressed in square inches. t is the thickness of the dielectric in inches. To ascertain the capacity in micro-farads (a micro-farad is one one-millionth of a farad), solve only that portion of the equation enclosed in parenthesis.

The joint capacity of several condensers connected on multiple is given by the following equation:

$$\text{Total } C = C_1 + C_2 + C_3, \text{ etc.}$$

The total or joint capacity of condensers connected in series is ascertained thus:

$$\text{Total } C = \frac{1}{\frac{1}{C_1} + \frac{1}{C_2} + \frac{1}{C_3}, \text{ etc.}}$$

The area in square centimeters for a condenser dielectric to have a certain capacity in micro-farads is deduced by this formula:

$$\text{Area in sq. cm.} = \frac{56 \pi D C 10^7}{K}$$

Where $\pi = 3.1416$ or pi.

D = the thickness dielectric in cm.

C = capacity in micro-farads.

K = the inductivity factor (see table).

$10^7 = 100,000$.

LESSON 20. "HOW TO MAKE THINGS."

The young experimenter generally finds himself sooner or later called upon to make the parts of various apparatus, models, attachments, etc., and in this chapter it is intended to deal with some of the more potent features that often prove stumbling blocks to the junior mechanic; such as laying out work, finishing it, drilling and tapping of screw holes, etc., etc.



Fig. 1.—The Divider.

It may be said that, primarily, the beginner should make it a point to master the art of laying off specific distances from a rule; using a steel scale if possible.

A good mechanic can lay off work on metal with an accuracy of at least 1/64 inch, and often 1/100 inch. The closest working by eye does not usually exceed 1/200 inch. For finer measurements than this, i. e., in the order of thousandths, or ten thousandths of an inch, recourse is had to an instrument known as a micrometer, which is used for all good machine work.

In Fig. 1 is seen a pair of dividers, or compasses, for striking

circles, spacing center marks, etc. The micrometer is shown by the cut, Fig. 2, at A. Its scope is a wide one, and it is regularly used for finding diameter of wire, twist drills, sheet metals, rods, and for innumerable other purposes. It ordinarily reads in thousandths of an inch, but by a simple set of graduations around the stem, termed "Vernier graduations," after their inventor, it is easily possible to measure the size of an object, such as a wire, in ten thousandths of an inch.

A word about reading the micrometer may not be out of place here. The adjustable part of the micrometer is a carefully cut steel screw, hidden inside the barrel, the pitch of the screw being 40 threads to the inch. Hence every time the barrel is turned through one revolution it advances or recedes from the anvil or measuring face 25 thousandths of an inch. This value is represented on the solid stem by single graduations. Every four graduations, or 100/1000 of an inch is indicated by a longer line, as seen by glancing at cut.

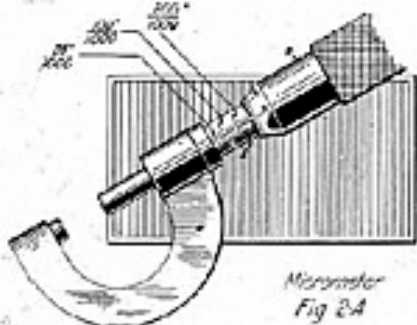

Micrometer
Fig. 2A

The reading in the figure is 300/1000, or 12 single divisions, which is 12 times 25/1000, or 300/1000. Note that when reading this value the zero mark on the revolving barrel is coincident with the graduated line along the solid stem. Odd fractions in thousandths are read by noting the number on the barrel index B coinciding with the stem line. For instance, suppose the barrel is unscrewed sufficiently to expose three single divisions and the No. 7 on the barrel index B was opposite the stem index line. Then the value of the caliper reading would be 3 X 25 thousandths (mils), plus 7, as read on the barrel index, or 75 and 7, which is 82 mils, one mil being equivalent to 1 thousandth of an inch. If the barrel index had been set so that the stem index line was midway between 7 and 8, then it could have been approximated as 75 mils, plus 7½ mils, or the reading would be .0825 inch, the ten thousandths figure being guessed at.

The easiest way to lay off work for machining, drilling, etc., on iron or steel is to cover it with a coating of chalk, which permits the lines scribed on the surface with a steel pointed instrument, so as to be readily seen. A scriber is easily made out of a piece of Stubb's steel, or drill rod, about 6 to 8 inches long and 1/8" thick. After grinding a fairly tapering point on the ends it can be hardened by beating in a Bunsen flame or other fire, to a red heat and then plunging into water.

All lines showing the size, location of holes, etc., are scribed out on the metal, previously chalked over, as aforementioned, or if on wood, simply by a hard pencil, and all centers of holes to be drilled should then be center punched by a hard steel punch. (See Fig. 3.) For measuring the inside diameter of a hole, or the exterior diameter of a drill or rod, use is made of outside or inside steel calipers, shown at Fig. 4; "a" being the outside caliper. These must be compared with a scale or rule after calipering a rod or hole. A little experience with these calipers, which are employed in all machine shops for measuring the diameter of shafts, journal boxes, etc., will enable the amateur to caliper quite closely. Some machinists can discern a difference of a few thousandths by means of these calipers, but for very accurate work micrometers are invariably used.

For cutting off small portions of soft iron and other odd work the hack saw, Fig. 5, using hardened saw blades from 8" to 12" long, is the usual tool employed. In using it too much pressure should not be exerted downward, as the teeth, being highly tempered, will break off, also the saw should be kept steady, not wobbling it, as it is swung back and forth.

A small drill press arrangement with a hand drill attached for boring small holes through metals, fiber, wood, etc., is seen at Fig. 6. The substance to be drilled is easily clamped on the bed plate attached. Further drilling accessories are illustrated at Fig. 7, "a" to "e." An automatic reciprocating ratchet drill for drilling thin sheet metal, leather fiber, wood, etc., is seen at "a," the different size drills being carried in the handle. A small hand drill with geared handle and capable of drilling 3/16" holes through iron or soft steel is depicted at B, while C shows a magazine tool handle with chuck clamping any of the tools displayed.

Tables giving size of tap drills for various machine screws are given in any tool catalog. The common sizes of machine screws and taps used are: No. 4, 5, 6; 4, 5, 6; 8, 32; 6, 32; 10, 32; 10, 24; 8, 24; 12, 24; 14, 20; 1/4"-20; etc.; the first numeral indicating the tap number and the second numeral the number of threads to the inch pitch.

(To be continued.)

Electricity and Nature—A Thunderstorm Primer

WHY DOES the rubbing of a stick of sealing-wax cause it to attract small particles of matter?

Because it excites in the sealing-wax that force which was first observed in the amber. Sealing-wax, therefore, is called an *electric* (amber-like) body.

from cold to heat; from a state of rest to that of motion; from the solid to the liquid, or the aeriform condition, or vice versa; or whether substances combine chemically and produce new compounds—in every change the electrical equilibrium is disturbed; and, in proportion to the degree of

excited, instead of a stick of wax, electricity would be equally developed; but the iron, being a good conductor, would pass the electricity to the hand of the operator as fast as it is accumulated, and the equilibrium would be undisturbed.

What is the effect when electricity in considerable force, seeks its equilibrium, but meets with insulating bodies?

The result is a violent action, in which intense heat and light are developed, and in the evolution of which the electric force becomes expended.

What is the cause of electric sparks?

The electric force, passing through a conducting body to find its equilibrium, is checked in its course by an insulator, and emits a spark.

What produces the electric light?

Currents of electricity pass towards each other along wires at the ends of which two charcoal points are placed. As long as the charcoal points remain in contact, the electric communication is complete, and no light is emitted, but when they are drawn apart, intense heat and light are evolved.

What is the cause of lightning?

Lightning is the result of electrical discharges from the clouds.

What develops electricity in the clouds?

Evaporations from the surface of the earth; changes of temperature in the atmospheric vapour; chemical action on the earth's surface; and the friction of volumes of air of different densities against each other.

Why do these phenomena produce electricity?

Because they disturb the equilibrium of the electric force, and produce positive and negative states of electricity.

When does lightning occur?

When clouds charged with the opposite electricities approach, the forces rush to each other and combine in a state of equilibrium.

Why does lightning attend this movement of the forces of electricity?

Because the atmosphere, being unable

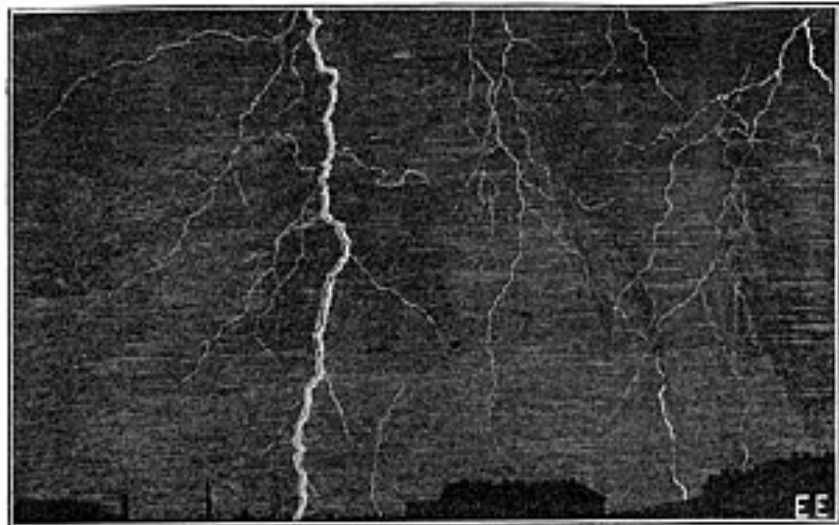

Spectacular Illustration of Lightning. Note the Several Divided Branches of the Discharges. Such Flashes May Involve Millions of Volts and Thousands of Horsepower.

Why is electricity termed the electric fluid?

Simply because the term *fluid* is the most convenient that can be found to express our ideas when speaking of the phenomena of electric force. But of the nature of electricity, except through its observed effects nothing is known.

What substances are electric?

All substances in nature, from the metals to the gases. But they differ very widely in their electrical qualities.

What is positive electricity?

Electricity, when it exists, or is excited in any body, in an amount which is in excess of the amount natural to that body, is called *positive* (called also *vitreous*).

What is negative electricity?

Electricity, when it exists, or is excited, in any body, in an amount which is less than is the amount natural to that body, is called *negative* (called also *resinous*).

Why is "positive" electricity called also "vitreous," and "negative" electricity called also "resinous"?

Because some philosophers believe that there is but one electricity, but that it is liable to variations of quantity or state, which they distinguish by *positive* and *negative*; while others believe that there are two electricities, which they name *vitreous* and *resinous*, because they may be induced respectively from *vitreous* and *resinous* substances and are found to display forces of attraction and repulsion.

Upon what do the electrical phenomena of nature depend?

Upon the tendency of electricity to find an equilibrium between its positive and negative states (assuming there to be but one fluid); or upon the tendency of vitreous electricity to seek out and combine with resinous electricity (assuming that there are two fluids).

How does the equilibrium of electricity become disturbed?

By changes in the condition of matter. As electricity resides in all substances, and is, perhaps, an essential ingredient in their condition, so every change in the state of matter—whether from heat to cold, or

disturbance, is the force exerted by electricity to resume its balance in the scale of nature.

How does electricity seek to regain equilibrium?

By passing through substances that are favorable to its diffusion; therefore they are called *conducting* or *non-conducting* bodies, according as they favor or oppose the transmission of the electrical current.

What substances are conductors of electricity?

Metals, charcoal, animal fluids, water, vegetable bodies, animal bodies, flame, smoke, vapour, etc.

What substances are non-conductors?

Rust, oils, phosphorus, lime, chalk, caoutchouc, gutta serena, camphor, marble, porcelain, dry gases and air, feathers, hair, wool, silk, glass, transparent stones, vitrefactions, wax, amber, etc. These bodies are also called *insulators*. Some of these substances, as chalk, feathers, hair, wool, silk, etc., though non-conductors when dry, become conductors when wetted.

Insulating—preventing from escape.

Why are amber and wax classed among the non-conductors, when they are pointed out as electrics, and used to illustrate electrical force?

It is because they are non-conductors that they display under excitement the attractive force shown in respect to the particles of matter which were drawn toward their substances. If a bar of iron were

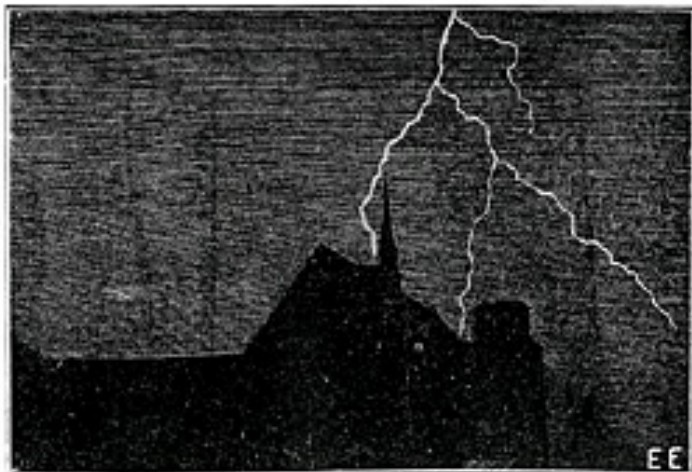

Showing a Single Stroke of Lightning From Cloud to Earth. A Return Stroke From Earth to Cloud Often Occurs. Hence the Futility of Staying in a Cellar.

to convey the great charges of electricity as they rush towards each other, acts as an insulator, and lightning caused by the violence of the electricity in forcing its passage.

Does lightning ever occur when the conducting power is equal to the force of electricity?

No; electricity passes invisibly, noise-

lessly and harmlessly, whenever it finds a sufficient source of conduction.

Why do electric storms purify the air?

Because they restore the equilibrium of electricity which is essential to the salubrity of the atmosphere; they intermix the gases of the atmosphere by agitation; they precipitate the vapours of the atmosphere, and with the precipitation of vapours, noxious exhalations are taken to the earth, where they become absorbed; they also contribute largely to the formation of ozone, which imparts to the air corrective and restorative properties.

Why does electricity accumulate in the clouds?

Because the clouds are conductors, but the air surrounding them is a non-conductor; when, therefore, electricity is excited in the atmosphere by any natural cause, it is received by the clouds; it is probably this electric charge which prevents the water vesicles from uniting together and falling down in the form of rain.

Why do different clouds become charged with the opposite electricities?

When two bodies are rubbed together they become electrified—one of them positively, and the other negatively. It is very probable that when two currents of dry air move in different ways, the friction of the two surfaces may evolve electricity. Clouds floating in the locality of the excitement would receive the electricity, and thus one cloud may become charged with positive and others with negative electricity.

Why do clouds when electrified, move towards each other?

Because bodies which are charged with the opposite electricities attract each other—the electricities always seek to establish an equilibrium and hence two electrified clouds would attract each other.

Let it be assumed that the cloud A becomes positively electrified—that is to say, charged with positive electricity. There is not in all nature, and there cannot be, such a condition as that of one body positively excited without the co-existence of another body negatively excited. Hence, if cloud B were away, and cloud A positively excited, the air circumjacent to A would assume the second or negative function; but if the cloud B is present, it therefore becomes negative, and the two clouds A and B are mutually attracted, because opposite electricities attract each other. Hence they approach until the space of air between the two is insufficient to restrain their mutual electric tension; this condition having arrived, a discharge takes place.

Why does a flash of lightning occur when the electrified clouds approach each other?

Because the air between the clouds is a non-conductor; it is the force of electricity overcoming the resistance of the atmosphere which occasions the flash of lightning.

Why does a shower of rain generally succeed lightning?

Because the equilibrium of a certain amount of electricity having been restored, the clouds, deprived of their electricity, collapse into rain.

Why does a thunderstorm sometimes cease after a few flashes, and a smart shower?

Because when the electrical changes occur only between clouds, the equilibrium of their electricities is soon restored.

Why does a thunderstorm at other times continue for a long period?

Because the air as well as the clouds are involved in the electrical disturbance. The air with which a cloud comes in contact, being a non-conductor, would not lose its electricity by the discharge of the cloud, but would continue to supply the cloud with new charges; and this repeated charging and discharging would continue till the dif-

ferent strata of excited air were brought to their natural state.

Does lightning ever pass from the air to the earth, and from the earth to the air?

Thunder-storms usually take place between the clouds, or different strata of air. But sometimes when clouds charged with an opposite electricity to that of the earth, or of a mountain, approach it, a discharge



Two Clouds, Charged with the Opposite Electricities—(A) Positive and (B) Negative.

takes place from the cloud to the earth, or from the earth to the cloud.

The mingling of the electricities of the earth and the air must be continually going on. But lightning does not attend the phenomenon, because all natural bodies, vapours, trees, animals, mountains, houses, rocks, etc., act more or less as conductors between the earth and the air. It is only when there is a great disturbance of the electrical forces, that terrestrial lightning is developed. When lightning strikes the earth with great force, it sometimes produces what are called fulgurites in sandy soils; these are hollow tubes, produced by the melting of the soil.

Why does the peal of thunder occur after the flash of lightning?

The flash and thunder are really simultaneous; but as light travels with a velocity immensely greater than that of sound, we see the flash sometime before we hear the thunder.

How may we calculate the distance at which the electric discharge takes place?

Sound travels at the rate of a quarter of a mile in a second. It, therefore the peal of thunder is heard four seconds after the flash of lightning, the discharge took place about a mile off. The pulse of an adult person beats about once in a second; therefore, guided by the pulse, any person

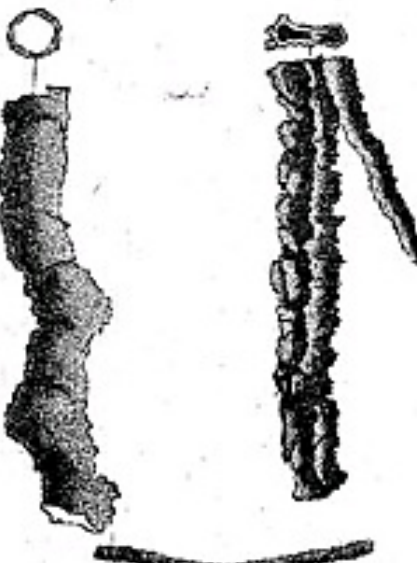

Showing the Very Peculiar and Striking Ferris Produced in Sand When Lightning Strikes It. Sometimes Called Lightning Tubes.

may calculate the probable distance of the storm:—

- 2 beats, $\frac{1}{2}$ a mile.
- 3 beats, $\frac{3}{4}$ of a mile.
- 4 beats, 1 mile.
- 5 beats, $1\frac{1}{4}$ miles.

- 6 beats, $1\frac{3}{4}$ miles.
- 7 beats, $1\frac{3}{4}$ miles.
- 8 beats, 2 miles, etc.

Attention should be paid to the direction and speed of the wind, and some modifications of the calculation be made accordingly. Persons between 20 and 40 years of age should count five beats of the pulse to a mile; under 20 six beats.

What is the extent of mechanical force of lightning?

Lightning has been proved to have struck a church, St. George's Church, Leicester, on the 1st of August, 1845, with a force equal to more than 12,000 horse-power. A single horse-power, in mechanical calculation, is equivalent to raising a weight of 33,000 lbs. one foot in a minute. The force of lightning, therefore, has been proved to be equal to the raising of 384,000,000 lbs. one foot in a minute. This is equal to the united power of twelve of our largest steamers, having collectively 24 engines of 500 horse-power each. The velocity of electricity is so great that it would travel round the world eight times in a second.

What gives the varying character to the flashes of lightning?

Lightning is zig-zag when it travels through a long-distance, because it compresses the air, which interferes with its direct course.

It is straight when it passes through a short distance only.

It is forked when, being resisted by the air, it divides into two or more points.

It is sheet when the flash is distant, and is seen by reflection in distant parts.

It is blue when the electrical excitement is very intense.

What is thunder?

Thunder is the noise which succeeds the rush of the electrical fluid through the air.

Why does noise follow the commotion caused by electricity?

Because, by the violence of the electric force, vast fields of air are divided; great volumes of air are rarefied; and vapours are condensed, and thrown down as rain. Thunder is therefore caused by the vibrations of the air as it collapses and seeks to restore its own equilibrium.

What gives the varying character to the sounds of thunder?

Its peals are most tremendous in mountainous regions. When interrupted in their advance by hills, or other elevated objects, the reverberation of the peals is broken and irregular.

They consist of a single and sudden clap when the storm is near, and when the country is level.

They are rattling and rumbling when the forked lightning occurs in different directions and distances.

Why is lightning sometimes unattended by thunder?

The absence of thunder sometimes arises from the great distance of the storm; at other times from the nearness of the clouds to each other at the moment of the discharge, occasioning but a slight disturbance of the atmosphere.

What is magnetism?

Magnetism is the electricity of the earth, and is characterized by the circulation of currents of electricity passing through the earth's surface.

What are magnetic bodies?

Magnetic bodies are those that exhibit phenomena which show that they are under the influence of terrestrial electricity, and which indicate the direction of the poles, or extreme points, of magnetic force.

What is galvanism?

Galvanism is the action of electricity upon animal bodies, and is so called from the name of its first discoverer, Galvani.

(To be concluded.)

OUR COVER.

By H. Gernsback.

The idea of our cover was conceived by the writer with the intention of inspiring the electrical experimenter at large. There is nothing fantastic about this cover; nothing impossible. It will all be very real in a comparatively short time. It is up to our experimenters to make it an accomplished fact.

The scene is laid near the coast in almost any part of the globe. The time, let us say, is in the year 2012. It is night. The large aerial system in the foreground radiates not feeble telegraph impulses but tremendous power. The power is furnished by the large "powerhouse" beneath the aerial system, some 30,000 kilowatts being radiated into the ether constantly. Naturally, such a tremendous power going into the air gives rise to peculiar phenomena. The air becomes luminous for several miles around and above the aerial. An inverted bowl-shaped light dome, with the aerial system as its center, is produced, and this light illuminates the landscape for miles around. The lower antenna acts partly as a reflecting aerial, which prevents the energy from being absorbed by the earth. It has been found that by using a curious vibratory pulsating wave of a tremendous amplitude almost no energy is lost in transmission through the ether, and for that reason the etheric power station as illustrated can supply energy within a radius of several hundred miles. The power is derived solely from the tides of the ocean—a tremendous force, which lay unharassed through aeons.

On top of the "powerhouse" we see two towers with curious light balls.

These are the "radiofers." You must understand that the "powerhouse" which shoots forth such a colossal force cannot be frequented by humans. As a matter of fact, no human being could come near the house, or within 500 yards. For that reason the power is entirely controlled from a distance, by wireless, of course. The control is exercised through the "radiofers."

In the left foreground we see a curious wheelless railroad. The cars float actually in the air, some feet above the broad, single iron track. The power is obtained from the distant power aerial by wireless, of course. One will notice the aerial wires on top of the cars, which receive the energy. The train is suspended by electromagnetism and glides smoothly along at the rate of some 500 miles an hour.*

In the left foreground also we see an immense 1,000-foot "optophor" tower. This tower shoots a dazzling colored light shaft of some ten million candlepower straight into the sky. Such "optophor" towers are stationed exactly 50 miles apart along the coasts, and every tower has a different colored light shaft. This light beam can be seen some 500 miles at sea, and by its light, transatlantic aerial, as well as aquatic craft, can steer with unerring accuracy toward their point of destination.

*In 1911 patent No. 1,023,042 was issued to Becketon on such a suspended train system.

RADIO "SONS OF REST."

Five Freeport, L. I., youths interested in wireless telegraphy and athletic sports, met at the home of Archer B. Wallace recently and formed a wireless club with the name, "The Sons of Rest." Donald Wallace was elected president, and Ralph Golden secretary-treasurer. Current periodicals and a library will be installed. The use of the $\frac{3}{4}$ k. w. transmitting set of the president is open to all members. The entrance requirements are an ability to receive at least five words a minute in the Continental code.

UNIQUE METHOD OF RECORDING THE VOICE.

A new method employing electricity and photography for making records of the voice has been worked out by Samuel Wein, of New York. His method will be better understood by reference to the illus-

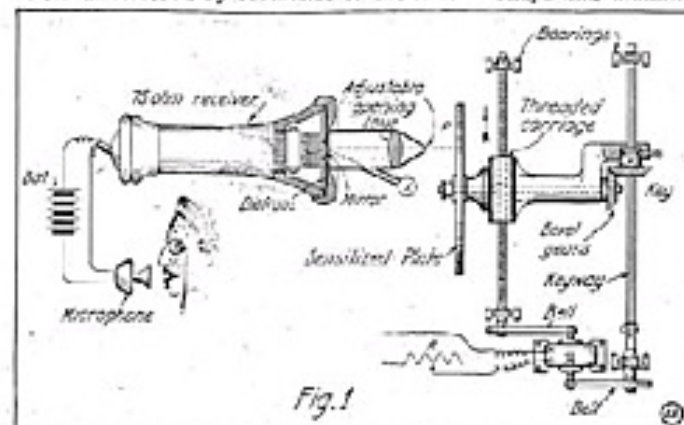

Scheme for recording the voice photographically.

trations herewith, Fig. 1 being the schematic lay-out and Fig. 2 the appearance of a photographic record. The particular record shown is that of a violin solo heard over the telephone circuit.

To proceed: The apparatus is, in general, arranged as shown at Fig. 1. Here a person talking (or any other sound) into a microphone transmitter sets up undulating electric currents by aid of the battery, which reach the ordinary telephone receiver of 70-ohm type as perceived. Instead of the receiver being utilized in the

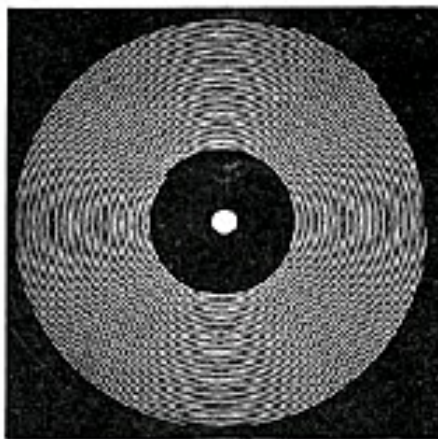

Fig. 2.

How the voice record appears as produced by beam of light

usual way to give acoustic reproduction of the voice waves, it has fastened to its diaphragm as indicated a very minute mirror. This mirror is illuminated by a beam of reflected light from a source X, the mirror at every movement of the diaphragm reflecting a spot of light through the lens and adjustable opening illustrated onto a sensitized moving plate P. The plate is kept close to the lens barrel orifice, by the way.

The recording plate P is caused to rotate and to move slowly across the light beam path so that a light spiral is photographed on the plate as seen at Fig. 2. It is claimed that this inertialess system of recording speech is superior to that now in vogue and employing a mechanical or stylog recorder, as then the friction and inertia of the recorder on the wax record makes it difficult if not impossible to register all the over and under tones.

In reproducing speech from the Wein

photographic record, two methods can be employed. The first is to make a copper etching from the photographic plate. Then a wax impression of the voice record is made by heating the copper plate and pressing it on a polished phonographic plate. A reproducing needle of proper shape and mounting is then able to follow

the voice groove with its attendant irregularities, and thus the voice is heard again. Another scheme is to reproduce the voice by a beam of light thrown against the plate containing the voice spiral photo, and rotating the plate as originally. Then as the varying beam of light filtering through the plate record falls on a selenium cell, the latter changes its resistance correspondingly, which is used to regulate or actuate

a telephone receiver with a battery in circuit.

NEW HYDROMETER READING AMPERE-HOURS.

The specific gravity change in the electrolytic solution of a storage battery has long been taken as the criterion of the state of charge or discharge of such cells and a new precision hydrometer recently introduced by an English manufacturer is arranged to give very accurate readings of the specific gravity, and by referring to a table provided the ampere-hour rating of discharge or charge. Any basic specific gravity value may be used. This instrument is shown in the illustration herewith.

As seen, it is fitted with a float of ample size, which rests on the surface of the electrolyte and the hydrometer stem protrudes upward through the float, which has a very sharp cut indicating scale on it, as the cut shows. Hence no meniscus fog can prevent accurate readings or also foaming or gassing of the electrolyte will not cause the errors usually occasioned when ordinary hydrometers are employed. This ampere-hour meter in hydrometer form has been adopted by the British Post-Office for storage cell maintenance. It is proposed in preference to voltage readings of secondary cells. For the practical owner and operator of such cells, it surely will be a boon.



RADIO OPERATOR, ILL, RIGS UP WIRELESS ON BEDSPRINGS.

Harry G. Cheatham, a wireless operator, while ill in the Carney Hospital, at Boston, Mass., with the assistance of a fellow operator rigged up a receiving apparatus, attached to his cot, and listened by wire to what was going on in the outside world.

Paul Helwig, Columbus, O., says: "Received my first issue of 'The Electrical Experimenter' and am very well pleased with it."

Electric Thawing of Frozen Pipes With a Gasoline Electric Motor Car

By Frank C. Perkins

THE accompanying illustration shows a gasoline-electric motor car and electrical apparatus for thawing out frozen water pipes as utilized at the Columbus Water Purification Works. On this truck is installed an engine of 50 H. P., operating at 800 revolutions per minute. This four-cycle four-cylinder engine is directly connected to an electric generator by a flexible coupling and a special governor was designed which permits of governed control at all speeds between 250 and 850 revolutions per minute. Gasoline is used for fuel supplied under 3 lbs. pressure from a 26-gallon tank.



Thawing Outfit Mounted on Truck.

The gasoline engine drives a generator of 30 kilowatts capacity direct current, 100 volts maximum, and giving 300 amperes or 400 amperes at 75 volts, the speed being 800 revolutions per minute maximum. It was decided that an output of 30 kilowatts would in most instances produce results in a time interval sufficiently short to render a heavier financial investment unwarranted, so that the outfit was constructed as above mentioned.

There is no doubt that one of the most difficult of the many problems in the maintenance of a public water supply system is that of thawing out frozen service pipes. A frozen underground service pipe can be freed from ice only by means of heat. The best method by which heat can be applied to, or generated in an underground pipe is to include the length of the frozen pipe in an electrical circuit which is carrying current of sufficient volume to raise the temperature of the pipe above the melting point of ice.

Several years ago this method was developed at the University of Wisconsin and is used in many cities to-day. The current ordinarily used for thawing the pipes is that of the public electric light circuit taken from cables at a voltage of something between 2200 and 6600 and carried to wagon-mounted transformers which reduce the current pressure to about 100 volts.

There are connections made to the frozen pipe in such a manner that the current is passed thru it, and the resistance heats the pipe sufficiently to thaw the ice. Last year there were an exceptionally large number of frozen service pipes in Columbus, and this made it imperative that some means other than the usual surface fires be tried to meet the trouble.

At first the Columbus Railway and Light Company supplied the current and furnished men to make the necessary connections and do the work in conjunction with the city employees. The results were very satisfactory and it was demonstrated beyond a doubt that the

use of electric current for thawing out frozen water service pipes produced results which were impracticable of attainment in any other manner. The majority of the thaws were made in from three to eight minutes of application of the current.

Altho good results were obtained with the above described apparatus, some serious difficulties were encountered in its use, as in some localities it was necessary to carry the wires a considerable distance in order to tap the high tension lines, and the work of bringing down to the street level alternating current at pressures of from 2200 to 6600 volts to connect with the transformers was dangerous at all times and particularly so in wet weather.

On account of this fact it was decided that the water department develop and construct this portable equipment, self-contained, safe and capable of being operated in any kind of weather, and the purchase of a motor truck of 2½ tons capacity was considered advisable on which to mount the thawing equipment during the winter months, while it would be possible to use the truck for other purposes during the remainder of the year.

It is claimed that three men only are required for operating the plant, and unless the locations are widely scattered, from 30 to 40 thaws per day can be made without difficulty.

A MAMMOTH NEW YORK

ELECTRIC SIGN.

Large crowds watch the "Kleanwell" toothbrush electric sign nightly in New York, it being located in the theatre section.

In action, the two Brownies pull at the

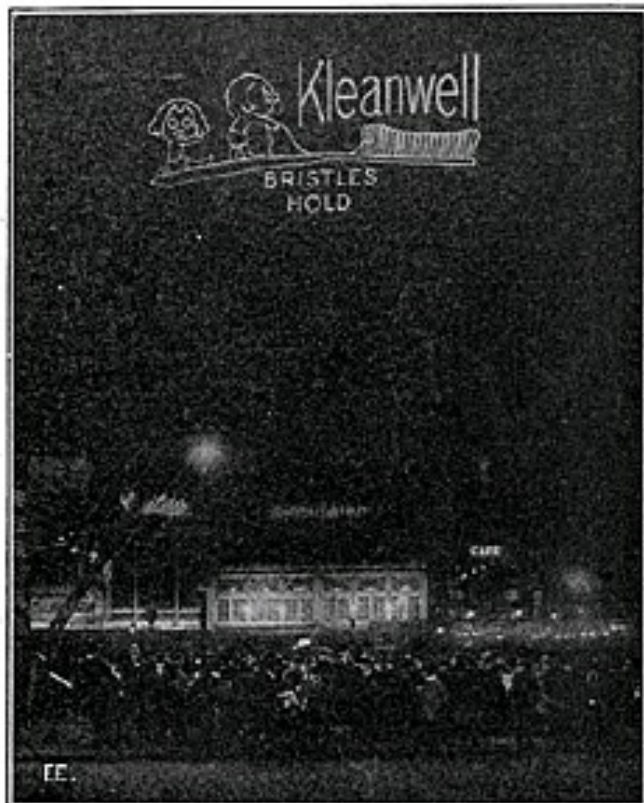

1,000 Tungsten Lamps Light This Sign.

rope, trying vainly to pull out the bristles. Finally the rope breaks; the second Brownie sits down hard and his eyes roll in astonishment. This display is 38 feet high by 90 feet long. The height of letter "K" is 18½ feet; height of bristles in brush, 10½ feet; height of Brownies, 23 feet; height of Brownie sitting down, 20 feet. More than 3,000 tungsten lamps are used in the entire sign. Incidentally, this is the second electrical display erected for the Kleanwell Toothbrush on Broadway by the O. J. Gude Co., and the manufacturers are frank to state the influence of the electric sign maintained for one year at 524 Street was remarkably far-reaching and results so satisfactory as to cause them to plan for this even bigger, brighter display just erected at Broadway and 43d Street.

NOVEL ELECTRIC RAT TRAP.

In a station on the Pennsylvania Railway, considerable trouble was experienced from rats till an electric trap in the form of an electrocuting "chair" was constructed. The "chair" consists of an iron plate with a steel spike suspended above it, both the plate and the spike being connected to the two wires of an electric circuit, preferably of 110 or 220 volts potential. The spike is baited with a piece of cheese and the rodents, in attempting to reach this, are promptly electrocuted.

NOTE

Beginning with this issue the price of this magazine on the news stands will be

10c.

The subscription price will remain 50 cents a year, until further notice.

If you intend to subscribe for the ELECTRICAL EXPERIMENTER, do it now. 2 years for \$1.00, 3 years for \$1.50, 5 years for \$2.00.

Whitecomb Monte, of Terre Haute, Ind., says of us:

"I would like to have you quote me a price on all the back numbers of the E. E. published before January, 1914. I feel that I need them in my business. Your dandy little magazine is more anxiously expected every month than any of the other high priced ones to which I am a subscriber."

CAN PLANTS FEEL AN ELECTRIC SHOCK?

PROFESSOR J. C. BOSE, of the Presidency College, Calcutta, claims to have isolated the nerves of plants and measured the degree of their reaction to a shock. For twenty years Professor Bose, who is an East

Indiar, says the *N. Y. Tribune*, has been studying various forms of vibration, such as invisible light and wireless telegraphy. For the last ten years he has been conducting experiments upon plants in order to determine their sensitiveness to stimuli such as excite animals and particularly human beings. His success with the delicate apparatus which he devised for the purpose has been so great that recently when he exhibited some of his experiments before George Bernard Shaw, that gentleman, who is so humanitarian that he is a vegetarian, exclaimed, "My God!"

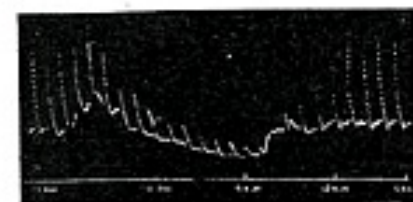

APPARATUS FOR RECORDING EXCITABILITY OF PLANTS

The mitigation of the sensations following the sudden discovery that no matter what we eat we cause pain to some other form of life was the task which Professor Bose immediately set himself. Whether his philosophy was sufficient to accomplish the task laid upon it cannot, perhaps, be stated, but the acceptance of the evidence that the sensations of a stolid carrot and of a live lobster upon being thrown into boiling water may be similar are not conducive to the comfort of an imaginative cook. Fortunately the apparatus of the scientist from the other part of the world has demonstrated that the sensitiveness of plants differs among themselves as it does in different species of animals, and is less intense than in such forms of animal life as have been tested for the sake of comparison. Moreover, Professor Bose points out, owing to the simplicity of the structure of the nervous system, the pain, or sensitiveness, is so diffused that it is not likely to be marked as in the case of the human being, in which it is concentrated in the impressions made upon the brain.

In view of the fact that no human eye before that of Professor Bose ever noted closely the effect of a shock on a plant, or ever demonstrated assuredly that a plant was capable of suffering pain, apparatus of a most delicate character had to be invented to detect and record the feelings of vegetation. Professor Bose devised two pieces, one for gaining knowledge of a plant's normal reactions and the other for recording the effect of shocks to its nervous system.

The former is operated by the electric currents generated within the plant itself. The impulses are indicated by a delicately adjusted circular mirror about the size of a dime, which flashes back and forth in accordance with the impulses communicated to it by the plant.

From the human point of view, however, having determined that plants do feel things and respond to them, the other instrument is perhaps of greater interest and importance. This is a com-

ination of clock work and electric currents. The clock work operates a sliding piece of smoked glass, upon which the plant writes its record, and at regular intervals gives the plant an electric shock. The record, which is made with a delicate lever upon the smoky surface, shows in hundredths of a second how soon after the shock was given the sensation reached the nerve centre and was followed by a reaction. It then records the recovery of the plant to its normal condition, the line of dots made by the rapidly falling leaf through its thread connection with the lever becoming practically a continuous line as the leaf more slowly returns to its normal position. As the slide moves at a regular rate of speed the rapidity with which the news of the shock was communicated through the protoplasm to the nerve centre and a reaction took place can be determined.

In a frog it has been revealed that a response is received within one one-hundredth of a second. In certain plants the time interval is six one-hundredths of a

?

Mr. H. Gernsback has written a new serial story:

Baron Münchhausen's New Scientific Adventures.

The story will begin in the next issue. Each number will contain a complete story by itself; there will be a new adventure each month. You cannot possibly afford to miss this.

Watch for the next issue. As there will be an unusual demand for the May number, leave your order with your newsdealer now, otherwise don't feel disappointed if he will be "sold out."

second. This tends to show that the nervous systems of animals are more sensitive, or better conductors than those of plants. The shocks are given through small wires attached to a stem and a leaf. Attached also to the leaf is a very slight thread, the other end of which is fastened to the recording rod. In order to overcome the retardation in the movement of the rod through friction while making marks on the smoked surface of the glass plate, the rod hangs free, making impressions only when actuated by a tuning fork attuned to its vibratory pitch.

When Professor Bose was experimenting for the edification of Mr. Shaw, he used a carrot. The terminals of two wires from a battery were inserted in its flesh. The carrot, Professor Bose counts one of the most stolid of plants. It is a regular "lunkhead,"

A THERMAL ELECTRIC WINDOW DISPLAY.

A new electrical device designed for window displays has been patented recently, which possesses considerable interest, as it produces motion without recourse to electric motors or electromagnets. Looking at the sketch, a number of metal balls 7, 7, etc., are seen resting on circular metallic rails. Now when an electric current of low voltage but heavy amperage or quantity is connected to these rails from a source *6* (which may be a step-down alternating current transformer or a battery), the current in passing through the rails and ball, causes a "bump" to raise on the rail as 10, in Fig. 4. Naturally this "bump" will tend to push the ball along, and as the ball progresses it is followed by a continuous heating and cooling of the rail as long as current is

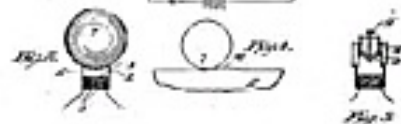
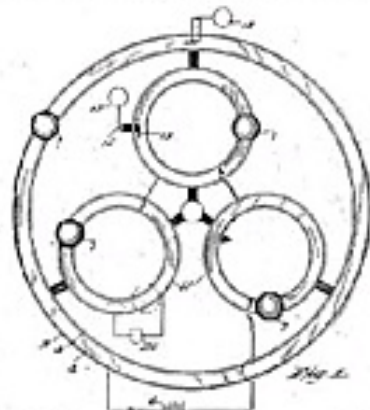

supplied. At Fig. 3 is shown how two wheels may be substituted for the ball and reciprocating motion given to a figure joined to the vertical rod *9*.

But when it was pinched with a pair of forceps, the light from the tiny mirror danced back and forth upon the frieze on the opposite wall. The shudder of pain, the sense tremors, were vividly portrayed.

One of the discoveries of Professor Bose is that some plants sleep. In the course of his studies of the mimosa, a plant whose leaves are so sensitive that they recoil from the touch of the hand, he found that for a period of three hours between 6 and 9 a. m. it was not to be disturbed. Cannons, so to speak, could go off close to it and it would make no response. Like a boy fond of his bed, it would pay no attention to the electric calls of the professor, who was probing into its life secrets. It would not get up or even open its eyes. So, in this respect, plants appear to be like human beings. They sleep.

In other respects also Professor Bose reports, they resemble mankind. They are affected by drugs. Placed in a small glass chamber and surrounded by the fumes of alcohol, the pulse shows stimulation, while the more stupefying drugs, such as chloroform, depress its action. If the exposure to the drugs continues too long, the plant will not survive. One curious thing which the experiments seem to show is that plants have no more fondness for carbon dioxide than have human beings. It has been generally supposed, and the supposition is backed (Continued on page 237.)

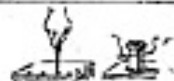
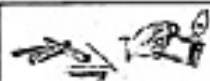

A SIMPLE WATER RHEOSTAT.

Many experimenters desiring a good water rheostat that can be used on model arc-lights on a 110-volt circuit or for other work requiring a medium-sized rheostat, can easily make one out of some odd battery-jars and dry-cell carbons that they might have around their laboratory.

The rheostat consists of two common

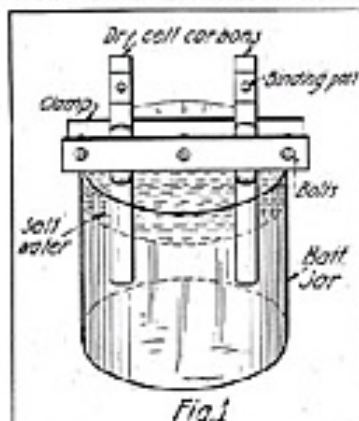
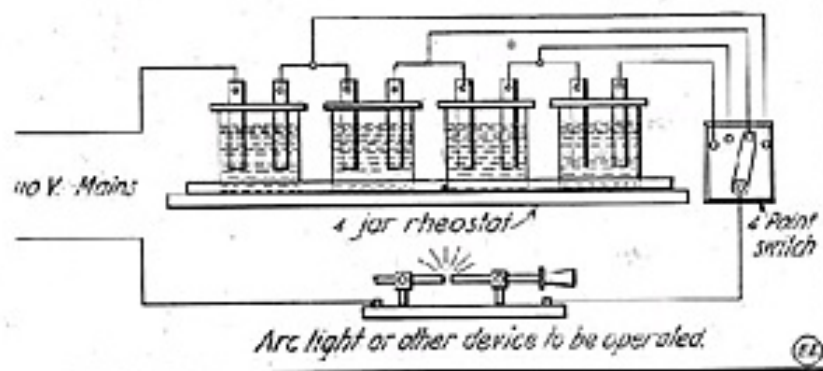

Fig. 1



dry-cell carbons held in a clamp and immersed in a solution of salt-water. Each clamp is made of two pieces of paraffined wood about 6x1x1/8". The carbons are clamped between these pieces of wood, about 3" apart, by three 2" stove bolts. The carbons are immersed in a salt-water solution which is contained in an ordinary wet-cell jar. See Fig. 1.

If the experimenter so desires, a battery of such rheostats may be made and set in a wooden tray. The connections for the rheostat are in the form of a simple series connection as in Fig. 2.

Contributed by

MAURICE P. DEMOTTE.

A 110,000 VOLT OSCILLOGRAPH.

For many years the Cambridge Scientific Instrument Co., of England, has been associated with the manufacture of instruments designed by Mr. Duddell, of which the oscillograph is perhaps the most widely known. The most interesting recent development along this line have been the manufacture of outfits to be used on extra high voltages. At the present time an outfit capable of being used on a circuit of 110,000 volts above earth potential is being constructed. Several outfits have been manufactured for use on 60,000 volt circuits, but this is the first one, as far as we know, in which voltages as high as 110,000 volts may be applied direct to an oscillograph without the intermediary of a step-down transformer.

OFFICE CALL FLASHLIGHT.

In many offices a bell or buzzer call signal is not preferred, and where a signal is quite necessary a flashlight indicator

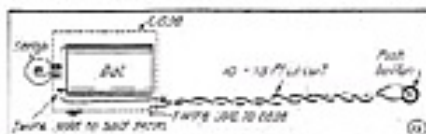

Pushing the Button Flashes the Lamp.

solves the problem nicely. Anyone can in a few minutes and with an ordinary battery flashlight, together with a few yards of No. 18 lamp cord and a push button, rig up a serviceable call circuit. If return call is wanted another lamp outfit, etc., must be used. The complete connections are clearly indicated in the sketch.

The push button connects to one end of the twin cord, and one of the cord ends at the lamp is soldered to the metal case (inside); the remaining cord terminal connecting to the short brass battery stem as shown. Every time the button is pressed the light flashes. Code calling is easily arranged for, as three flashes for A party,

two flashes for B party, one flash for C party, etc. Many other uses of this silent calling signal will suggest themselves to office people, for use in sick quarters where quiet is very essential, etc. One wire only need be run, the ground through a water-pipe being utilized for the return of the circuit. If circuits over 60 to 75 feet long are necessary, extra dry cells can be connected in series with the circuit as shown at X.

Where a reflector is placed over a desk a red lamp may be used for this circuit, fastening the red bulb under the reflector also. The reflection of the red light will be seen readily on the desk. Flash signals are good for calling stenographers, as a buzzer or bell signal is rather unpleasant in most cases.

A HANDY RADIO CIRCUIT.

Frequently it is desirable to change quickly from long to short wave length and vice versa, so that while waiting for a certain long wave length station to start sending, the time can be used listening to short wave lengths and yet run small risk of missing the start.

The accompanying circuit was designed for this purpose and found to work very well.

R is the receiving transformer, L₁ the loading inductance, V₁ and V₂ variable condensers. To the left is the long wave length position of the D. P. D. T. switch, and to the right the short wave length position.

When using this arrangement, the sliders or switches on the primary and secondary are placed in position found by experience to give the best results.

The loading coil and secondary variable condenser are then set to the wave length of the station expected.

With the switch in the short wave length position, the primary variable condenser is adjusted to tune in the amateur stations as wanted.

At suitable intervals, the switch is thrown over to the long wave length position and if that station has not started the switch is immediately returned.

The following suggestion will assist in making adjustments. First, get the secondary switch on the point ordinarily used for amateur wave length; second, set the primary slider in such a position as will give the strongest induction on the secondary; third, this position ordinarily corresponds to a longer wave length than the secondary is set for, so by means of the series condenser, the capacity, and hence the wave length, is reduced; fourth, this position ordinarily does not correspond to very long wave lengths, so by means of the loading coil, the inductance and hence the wave length is increased; fifth, since this adjustment makes the wave length of the primary exceed that of the secondary, the wave length of the secondary is increased by introducing a shunt capacity; sixth, with these adjustments properly made, operating the D. P. D. T. switch changes both the primary and secondary wave length by the same amount.

With some loose couplers the secondary coil is not variable and the full primary should be used for best results if the loading coil can be ad-

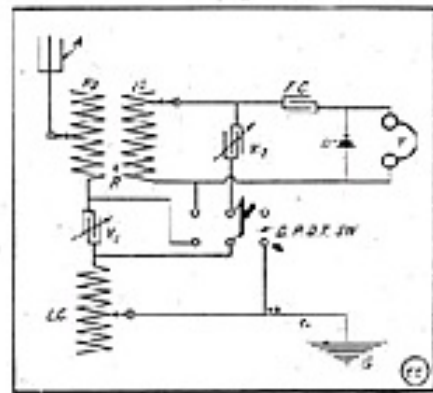

Throw-over Switch for Short and Long Wave Tuning.

justed in small enough steps. If the loading coil is adjusted in large steps, the position of the primary slider is fixed by it and the other adjustments will have to be made accordingly.

Submitted by

PAUL F. SHNEY.

Master Gussy Nagel, of New Rochelle, N. Y., says:

"I am very much interested in electricity, and very fond of experimenting. I am going to get regularly that magazine of yours *The Electrical Experimenter*. I think that it is a very instructive magazine. I have shown it to one of my friends, who also is very fond of electrical experimenting, and thinks it is a good one. I like to make odd and new things, such as buying motor parts, etc., and putting them together myself."

The Electrical Experimenter's Switch-Board

By Thomas W. Benson

NOTHING is handier in the experimenter's laboratory than some means for quickly and easily supplying currents of various strengths or voltages.

Therefore in this treatise I will describe two very handy switch-boards. One describes a board to handle 110 volt lighting current and this board will supply either D. C. or A. C. current at a wide range of voltages. The other board is for handling battery current.

No dimensions are given for the boards

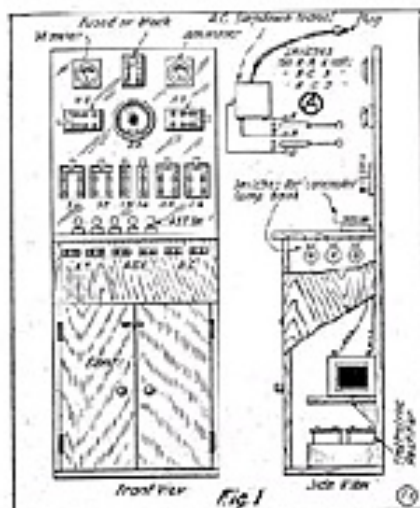

Front and Side View of 110 Volt Switch-board.

as you may not want to use all the instruments mentioned or you may have ideas of your own you wish to incorporate.

I will first describe the large board using 110 volt current from the lighting mains:

To cut down the voltage you may use a step-down low voltage transformer, giving you 3, 6 or 9 volts by manipulating the switches as per Fig. 1A. This is the best way, but an easier and perhaps cheaper method is to use a lamp bank consisting of twenty lamps (standard 110 volt, 16 C. P. lamps), wired up per Fig. 2. This diagram is plain enough, I believe, for everyone to understand its operation. By closing the proper switches from .5 to 10, amperes may be drawn in steps of .5 ampere.

For direct current you will require an electrolytic four-jar rectifier; altho a single jar may be used if the amount of current you will require is not heavy. The efficiency of one jar is very low, as only one side of the cycle is used or rectified. As a rectifier gives pulsating current for any experiment requiring a strong, steady current, you will require storage cells. The choice here will lie with yourself. If your demands are heavy, only a 6 volt 60 ampere hour battery should be used; but if the demand is light and the pocketbook is an important factor, use 2 volt, 20 ampere hour cells. Three of these will give you a 6 volt battery with 20 A. H. capacity.

These are to be charged from the power mains thru the rectifier, using the lamp bank to regulate the current.

The meters shown consist of voltmeter and ammeter of the "Electro" magnetic vane type. By means of the switch arrangement shown, you can plug them in and read the voltage and current in any of the several circuits and when arranged as in Fig. 3, they may be removed from

the switch-board and used in experiments right on the table, thus multiplying their utility.

The switch-board shown will fill all the needs of the average experimenter and will form a most compact form of control, following the design principle used on the Central Station boards.

Looking at Fig. 1, the method of operation is as follows: Have all switches open, close main switch, then close S1; then by adjusting switches for lamp bank, low voltage alternating current can be drawn from binding posts marked A. C. To read the voltage of this, throw VS to the left.

If you want direct current, close S2 and S3; then pulsating direct current may be drawn from posts P. D. C. To read the voltage of this circuit, throw VS to the right and close S6, and to read amperage, throw AS to the left and open S3.

Closing S5 charges the storage cells and care should be taken to get the rectifier and the storage cell wired up right or damage to the storage battery will result. Always open S5 before S2 so the battery will have no chance to discharge back into the rectifier, altho this is not very important.

Throwing AS to the right enables you to read the amperage of the storage battery both on the charge and discharge, which can be regulated by the rheostat regulator. To discharge battery, close S6 and draw current from posts marked D. C. The voltage of this storage battery is taken by throwing VS to the right.

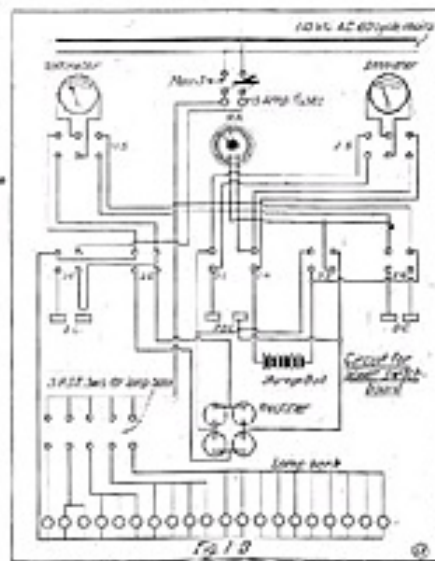

Circuits for 110 Volt A. C. Switch-board.

Carefully study the diagram and the above operations will become natural and no thought will be necessary in operating the board. It is advisable, tho, to label the switches.

A switch-board for the fellow without current in the house will be somewhat simpler, but such a range of currents will not be available.

In Fig. 2 is shown a simple switch-board similar to one I have used with great success for handling batteries. On the right are storage cells and on the left dry cells. Bichromate cells may be used instead of storage and a set of Gordon or Edison primary cells could displace

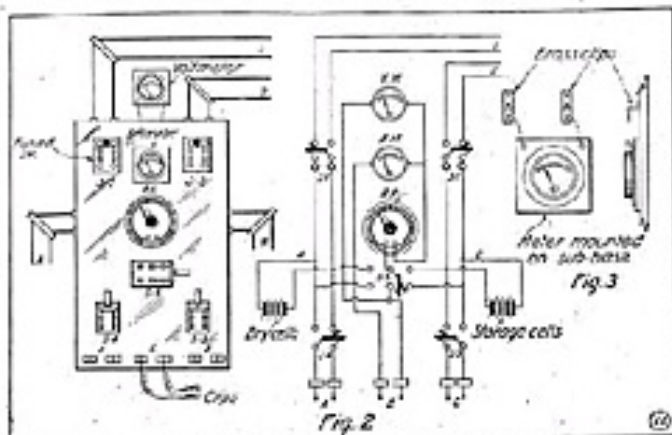

Switch-board for Battery Current Supply.

the dry cells with the best of results.

The voltmeter was not mounted on the board but on the wall above; two leads are run down in back of the switch-board (which, by the way, is kept away from the wall by a porcelain knob at each corner) and terminated in spring clips used for testing circuits, grounds, etc., by connecting one cord to one binding post, as shown above, while the remaining cord and a cord from the other post are used as contacts. A deflection of the needle indicates a closed circuit. The voltage in any of the circuits may be read by connecting the two clips to the binding posts.

In using this board, S₁ is closed; the circuit operating my telephone system, front door bell, gas lighting and miniature lights thruout the house, while S₂ connects the storage cells with my wireless set (Circuit 2, Fig. 2).

By S₃ it is possible to draw from either the storage or dry cells and to control it by means of the rheostat regulator R. R. Switches S₄ and S₅ enable you to draw current direct, without the regulator or ammeter being in the circuit.

These switch-boards will, I believe, cover the general run of amateur requirements except for the fellow who wants to pass 50 amperes at a time thru an electric furnace or the scientist who heats microscopic specimens by electricity. Of course, these would require special controlling apparatus.

The amateur building one of these boards will find his time well spent and his pocketbook will remain fairly healthy, considering the great convenience attained by their installation and use.

CHEAP CONDENSER PLATES.

Ask your photographer for some old negatives which he will probably give you or sell very cheap. Put them in a pan and pour hot water on them to loosen the gelatine on them; so that it can be readily scraped off, and you will have a good condenser plate.

By RAYMOND E. HOYNE.

Electric wiring will be taught in the public schools of Louisville, Ky.

PRODUCING ELECTRIC SLEEP OR ANAESTHESIA.

The art of producing artificial induced sleep or anaesthesia is one of the latest triumphs of electrical science, and is due to the researches and experiments of Prof. Stephen Leduc, of France, who tried out its merits on animals and human beings with marked success.

Since Leduc's experiments numerous

ply or outer edge is secured two brass segments, covering 18 degrees of circumference each, which gives a contact with the stationary brush F, of 1/10 period, a period occupying the space of 180 degrees, with a motor speed of 3,000 revolutions per minute, or four segments, each occupying nine degrees of the periphery if the motor speed is but 1,500 per minute, or 25 per second, causing four interruptions of the current per one revolution in this case,

offer but little resistance to the passage of intermittent direct currents, and so they have a chance to create a strong influence in these portions of the body.

In applications to human beings the current intensity required is approximately 35 volt and four milli-amperes (.004 ampere). The two electrodes are applied to the skull, shaving the points of contact closely before attaching the electrodes.

In experiments on rabbits the electrodes used were from 1½ to 1¾ inches in diameter, and for dogs they were from 2 to 2¼ inches in diameter. No ill effects were noticeable in experiments lasting several hours. The awakening occurs as soon as the electrodes are withdrawn, the actions being the same as in natural sleep, with the added advantage of increased mental and physical vigor on awakening.

Electrical anaesthesia, when utilized to render certain portions of the body insensible to pain for minor surgical operations, is applied by placing the negative electrode on the spot to be rendered numb, while the positive electrode is usually ap-

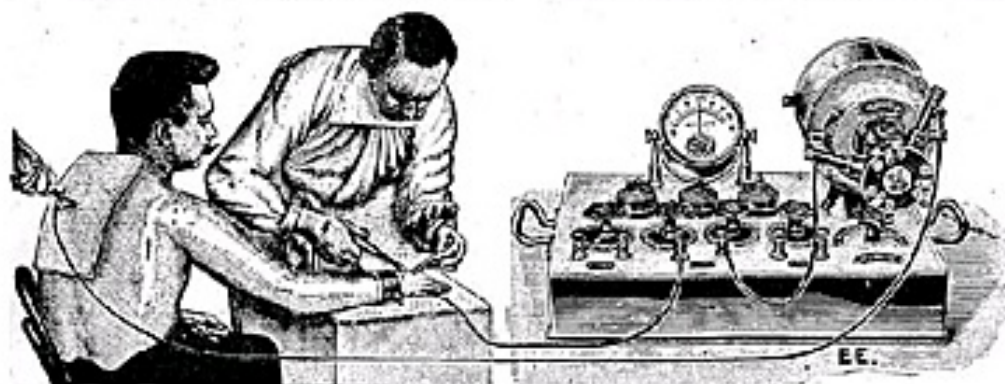

Fig. 1. Showing application of electrical anaesthesia.

tests and applications of electrically induced anaesthesia have been carried out to ascertain its fitness as a substitute for the older and unpleasant anaesthetics. Considerable work has been done along this line by Dr. Louise G. Robinovitch, at New York, the results being very successful, particularly as there are no ill after-effects or sickness to be noted. The current used to bring about these effects is a direct one, passed through a motor-driven interrupter, which breaks the current at the rate of 100 pulsations per second, or 5,000 per minute. The duration of current at each impulse is best when it is left on for 1/10 period and cut off for 9/10 period; hence, the actual duration of each impulse is 1/1000 second.

The method of applying the electric current may be such that only local anaesthesia, necessary in some surgical operations, is caused, or it may be general, resulting in complete sleep or loss of sense. A cut illustrating the manner in which local anaesthesia is applied appears at Fig. 1, while the other cut, Fig. 2, portrays a rabbit put to sleep by electricity.

The way in which the required periodicity of interruption is usually attained is to drive a special timing disc, containing two or more segments, which make contact with brushes bearing on it, the driving power being derived from a motor of the proper speed or other prime mover. The disc is attached directly to the motor shaft, and the motor must rotate at constant speed, and as A. C. motors, especially of the synchronous type, have quite a uniform speed, they are generally employed. If the voltage of the D. C. supply is sufficiently steady, a D. C. motor of the shunt or compound type can be made to do duty, but in many cases it fluctuates severely and is unfit for this purpose.

About the simplest method of obtaining the requisite speed and constancy is to operate the driving motor, of about 1/16 horsepower D. C. type, shunt wound, from a few cells of storage battery, which supplies a steady current, the strength of which is readily controlled by a variable resistance inserted in the armature circuit or main motor circuit, and this directly affects the speed of the motor.

A diagram, Fig. 3, shows the scheme of constructing the rotating disc so that it will interrupt the current properly. In the sketch A represents a circular disc of ¼ or ⅝" fiber or hard rubber, in whose per-

and two interruptions per one revolution with the speed of 3,000 r. p. m.

The brass segments are best fastened to the fiber disc by counter-sinking its leg as shown at H, securing it with two 8-32 flat-head machine screws tapped into the disc.

The stationary contact brush F may be a square fan motor brush, of woven wire preferably, fastening the brush holder in the proper position by means of a fiber arm screwed to the top of the motor. The connection to this brush is clamped or soldered to the metal holder. This brush must not be wider than the length of the segment on the disc.

The extra timing brush G is made of about ⅛" thick spring brass or phosphor bronze strip, having its one end bent at right angles as depicted in cut, where it rests on the disc. This is to allow of placing it close up to the other brush F at the start.

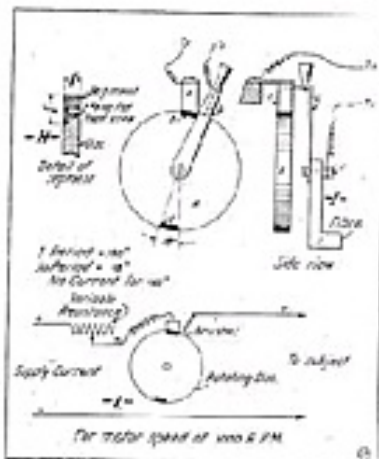

Fig. 3. Diagram of timing disc and circuit for producing electric sleep.

The timing brush G is arranged to swing concentrically about the periphery of the rotating disc by mounting it on a pivot in the fiber block J, where K is a machine screw serving as a pivot. Connection can be made to the brush G by simply soldering a flexible wire lead to arm.

The connection of the various parts to the circuit is shown in the diagram L.

The philosophy of electric sleep production lies in the fact that the brain and skull

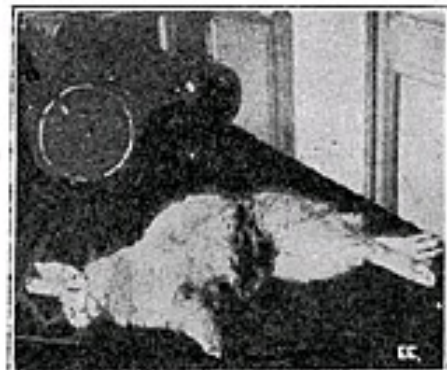

Fig. 2. Rabbit put to sleep by electricity.

plied to the corresponding spinal nerve center.

The current employed in producing local anaesthesia is about two milli-amperes (.002 ampere).

100,000 VOLT DIRECT CURRENT X-RAY MACHINES.

(Continued from page 213.)

The wave "C" shown, between Nos. 1 and 2 is the character of alternation. Assume No. 1 is of positive (+) polarity in that instant. The direction of the flow is then shown by the arrows. The wave form after rectification is shown between conductors Nos. 3 and 4. In Fig. 4, "D" is shown the next alternation and reversal. The disc has now changed its position from Fig. 3 to Fig. 4. Conductor No. 2 is now positive and the current flows as shown by the arrows. It can be seen that all the positive (+) impulses are conducted along No. 3, and the negative (-) impulses along No. 4, thus giving absolute unidirectional current.

The large machine depicted at Fig. 5 is a special deep therapy unipulsating generator, and the micaite rectifying disc is plainly seen, the driving motor being located behind it. The control switchboard is separate from the machine proper, and the step-up A. C. transformer is shown at the base of the apparatus, with its two 100,000-volt secondary terminals leading up to the rectifying disc. Very little loss occurs in these devices.

NOTICE!!!

We wish to buy May, '13, Oct., '13, and Jan. '14 copies, "E. E." Address the Editor.

COMMERCIAL RADIO TRANSMITTING CONDENSERS.

CONDENSERS used in wireless transmitting stations of commercial type as installed by the Marconi Wireless Telegraph Co. are illustrated herewith, as well as the metal rack for holding eight jars for a 2 K. W. set. The jars of the shape depicted rest at their base in metallic spring cups, which serve

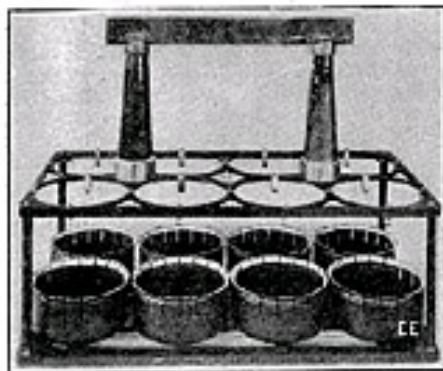

Commercial Condenser Jar-Rack. 2 K.W. Size.

as connections to their outer copper coating. The upper part of the frame also carries four springs around each jar opening to further aid in supporting same. Hence with all eight jars in place all of their outer coatings are connected as one pole. The inside or opposite terminals of the jars are connected in any way desired, i. e., in parallel, series-parallel, etc. The center bar shown raised on tapering insulators is for carrying the connections.

Concerning the Leyden jars used in these frames, each has a capacity of about .003 micro-farad, and measures 5 inches outside diameter by 16½ inches high. As the illustration shows, the neck tapers into a small diameter which measures 3½ inches. The glass of the best quality and charge retaining powers is ¼ inch thick. The copper



Section of Leyden Jar

coating which extends up about three-quarters the height on the inner and outer surfaces of the jar is plated or fused right onto the glass, thus insuring the minimum trouble from blistering, or air bubbles under the coating which are always conducive to rapid breakdowns from electric strain.

The copper coating on such jars is accomplished usually by sand-blasting the glass surface inside and outside, and then a coating of some strongly adhesive substance, such as powdered plumbago, is sprinkled over the roughened surface. The jars can then be placed in a copper-plating bath and finished up.

Another copper-plating method is that of Wein, and in process the metallic coating is firmly and surely burnt into the glass with no air bubbles. In brief, the glass, in jar or plate form, is placed in a special heating and annealing furnace, where the heat is raised to 1,600 degrees Fahr. or more, or approximately the fusing point of each glass employed, and silver is fused

A NOVEL AERIAL FOR RADIO EXPERIMENTS.

Philip E. Edelman.

The writer erected a novel form of aerial recently in order to carry out some experiments. In previous experience with portable and kite sets it was found that limitations of field sets were not adapted to accurate experimental work; so in designing this form of aerial it was desired to secure both a good ground connection and ample station facilities, while at the same time it was desired to secure all the advantages of readily altered aeriels and the variable heights allowed for portable aeriels.

As an illustration of the value of this type of aerial, the following example is given:

A single aerial conductor is stretched horizontally over an adjoining open field and led into a permanent station in the usual manner. All the necessary apparatus and measuring instruments are located conveniently at this station. Aerials of any desired shape and size are then erected to any desired height in this field and connected to this single long lead-in. Kites have been used for this purpose. The kite is flown in the usual manner and the aerial wire played out to any desired extent. Then it is a simple matter to secure connection from the kite aerial to the permanent station by simply running the wire suspended by the kite against the long lead-in which runs into the station.

Surprising results can be obtained in this manner. A new form of aerial is in reality formed for the substantially vertical kite-suspended wire added to the horizontal lead-in gives entirely new types instead of inverted types, such as a true "L," inverted "T," extended "Y," etc. Such aeriels are decidedly not freaks, because in the manner described they possess both good electrical properties and a practicable construction.

With a kite wire as fine as No. 28 suspended 900 feet vertically as above, messages have been intercepted from a distance of 2,000 or 3,000 miles, and at other times considerable charges of static electricity have been available near the grounded end. In repeating or extending these experiments it is necessary to use caution.

At present the true "L" appears fully as good as the inverted "L" and in practice it would probably be easier and cheaper to construct, as only one very high support is needed in place of the many high supports required for an extensive inverted "L" system. It appears that the true "L" is exactly the right form to conserve the maximum static and magnetic received energy. It is believed that this true "L" is new to the art and that it may prove to be of value.

onto the glass surface in this manner. After cooling the silver (burnt in) coat is copper-plated as heavy as desired. The plating so deposited is very tenacious and cannot be scraped off in the ordinary way, even with a razor blade.

C. L. Robinson, of Laquey, Mo., writes: "I received the March *Electrical Experimenter*. I am very much delighted with your magazine. I have read several, but it is the best I ever saw for the general electrical and wireless experimenter. Success to you."

TESLA HAS WIRELESS TO LIGHT WHOLE OCEAN.

"I have invented and patented an apparatus for transmitting electrical energy without wires which will not only revolutionize the present wireless systems, but will make it possible to cast light from shore that will make the Atlantic steamship lanes safe," declared Nikola Tesla, on his return from Washington recently, where the invention was patented.

He stated that his apparatus would give the wireless unlimited sending power and messages around the world.

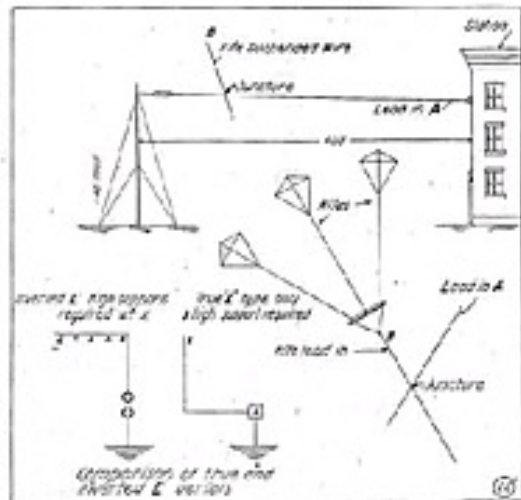

would be a matter of course. With a plant in the Azores he said he could project light rays over the Atlantic Ocean.

AN ELECTRIC FROST ALARM.

(Continued from page 212.)

spots in the orchard, and in these locations the thermometers are placed. These tests to locate the coldest spots will prove to the grower that a very appreciable variance of temperature exists within a small radius, thus emphasizing the necessity for accurate thermometers in different parts of the orchard.

The thermometer is attached to any stout post or convenient support from 3 to 6 feet in height. The wire is not allowed to come in contact with any wire fence, telephone or electric wires. The following temperatures are injurious to the fruits mentioned when in bud and blossom:

	Setting Other			
	3rd. Deg.	4th. Deg.	Frost. Deg.	Time. Deg.
Grapes, Tangerines.....	31	31	31	28
Grape Fruit, Lemons,				
Oranges, Eng. Walnuts...	30	31	31	28
Plums, Prunes.....	30	31	31	28
Almonds.....	28	30	30	20
Peaches.....	25	30	30	28
Apples.....	25	30	30	20
Pears.....	28	29	29	28
Strawberries.....	28	28	28	20
Tomatoes, S. Potatoes...	31	31	31	22
Irish Potatoes.....	30	30	30	22

The frost alarm annunciator consists of thermometers in weather proof cases 12 in. x 2 in. arranged to ring an alarm at 32° F. or any other permanent point desired and includes a special relay attachment, batteries, electric bell and annunciator, the latter showing location from which the alarm has been given.

THE MIGNON RADIO COUPLER.

A radio receiving tuner which operates on an entirely new principle is the Mignon vario-selective coupler. Its appearance is illustrated by the cut, Fig. 1. The variation of inductance in its windings is effected by rotary switches entirely, which feature is found on but few instruments of this type to-day. This feature is one of its good



points. A loading inductance, primary and secondary, are provided in this coupler, the tuning to any wave length from a hundred

meters to 3,500 being done quickly and easily by turning the rotary knobs. Its cabinet is extremely small, measuring 8x8x1 1/2 inches, with a weight of two pounds. This instrument is of the variometer type, similar to the Telefunken variometers which are so efficient. The arrangement of the circuits are outlined in Fig. 2, which are the standard ones. The dotted lines indicate how additional tuning apparatus may be connected to the Mignon set.

Looking at Fig. 2 we see that there are three divisions of the winding, viz., the loading inductance, L1, the primary coil, P, and the secondary, S. The 2,000-ohm head 'phones are connected across the binding posts marked "Receivers." The aerial and ground are connected to the posts labeled A and G. Detectors are connected at posts marked Det., and if a "Radioson" or other battery type detector is employed, a switch should be placed at X in series with the detector. Variable timing condensers may be connected at V. C. 1 or V. C. 2, or both. For ordinary work the coupler is used without any blocking or fixed condenser across the 'phones as at J. C., but for long distance reception a small capacity should be joined across the 'phones. Great efficiency is obtained here, as the windings are very close and also they are metallically joined together. Again, the loading inductance is a part of the coupler coils and thus realizes the best efficiency possible; all

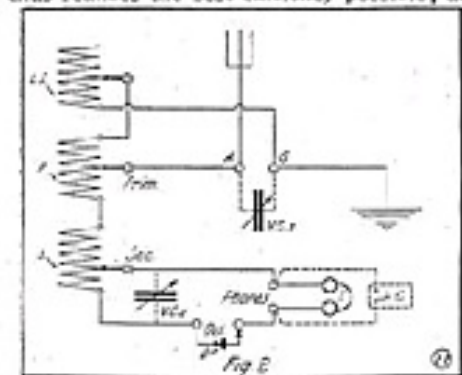

the active turns in any case working together in a common field. This set, with 2,000-ohm 'phones and a good detector, make a handy one for jewelers in receiving the radio time signals.

D. Frederick Primm of St. Louis, Mo., says:

"I received your free copy of the Electrical Experimenter for which please accept my thanks. I find this paper very interesting and just the thing for the Experimenter."

W. R. Cottrell, of Prairie City, Iowa, says:

"I think your magazine is great and hope to see it enlarge along its chosen path."

D. L. & W. RAILROAD WIRELESS.

The Scranton, Pa., wireless installation of this railroad was covered in an illustrated article in the February number of *The Electrical Experimenter*. The towering steel mast at Hoboken, N. J., attracts the attention of all passengers on passing ferry boats on the Hudson river. It has a height of 401 feet and is extremely simple in design, as may be seen from an inspection of the picture, follow-

ing Marconi practice along this line. The antenna extends from the top of the skeleton steel tower to the tower on the ferry house, shown at the left, the distance between the two points being 600 feet.

The view of the interior of the radio operating room shows the completeness and substantial character of the equipment. The station has a five-kilowatt outfit, and a wave length of 2,800 meters is normally used.

The system is in those operating order and communication is had with Buffalo and Binghamton, N. Y., Scranton, Pa., and those express trains en route that are equipped with wireless apparatus.

The interior of radio station at Hoboken.



The large aerial in the D. L. & W. yards at Hoboken, N. J.

ITALIAN NAVY RADIOPHONE.

The wireless telephone adopted by the Italian navy, designed by H. J. Round, a Marconi engineer, has a guaranteed range of forty miles. In "calling up," a signal is sent by an aerial wave so attuned that it gets in motion a certain pendulum, thus ringing a bell, and by the varying strengths of the waves, the sender is able to act upon any one of about twenty pendulums, and to ring any one of the receivers without having the call heard by the nineteen others. When connection is established, conversation is said to be easy over distances up to forty miles or more, except during thunderstorms or like electrical disturbances.

HAMMOND RADIO BOAT GOES 56 MILES.

The wireless torpedo boat, invented and perfected by John Hays Hammond, Jr., at his laboratory, near his father's home, has been tried out before Colonel Hann, U. S. A., and a delegation of military and naval men. Later the government will give the apparatus an official test.

The craft was driven from Gloucester Bay to the Graves, off Boston light, a distance of twenty-eight miles, where it was controlled perfectly and brought home again entirely by electricity.

On a dark, foggy night it would be possible to work this craft against a battleship. It could also be operated from a warship. Mr. Hammond plans to make his boat practically a submarine.

WIRELESS TRAVELS 175,000 MILES A SECOND.

The Naval Observatory at Washington, D. C., has completed the reduction of the observations for the direct determination of the difference of longitude between Washington and Paris, made last winter by its parties, and finds it to be 5 hours 17 minutes 36.658 seconds.

The velocity of transmission of radio signals given by these observations is 175,000 miles per second, which is probably the best value yet obtained, though owing to the distance—3,831 miles on a great circle—between the stations, which, compared with this velocity, is small, it is subject to a probable error of 16,000 miles per second.

These observations constitute the first direct determination of the difference of longitude between Washington and Europe, and it is the first time that radio-telegraphy has been used for transatlantic longitude determinations. Independent observations were made by the United States and French Governments, each having two parties, (which exchanged station at the middle of the observations), one at the United States Naval Observatory, and the other at the Paris Observatory, using the navy radio station at Arlington and the Eiffel Tower, respectively, for radio transmission.

The D. C. Arc for Wireless Telegraphy and Telephony*

The subject of my lecture this evening is "The Use of the Direct Current Arc for Wireless Telegraphy and Telephony." As the subject is rather a wide one, I shall divide my lecture into three parts.

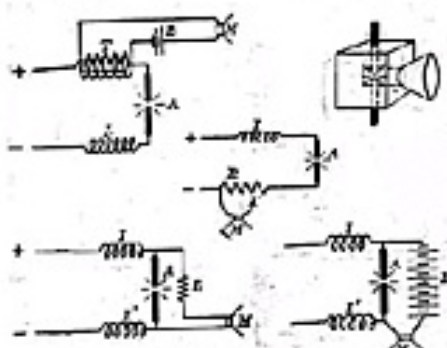

Fig. 1

In the first part I shall deal with the electric arc as a telephone receiver. In the second I will show how the arc is used as a generator of high-frequency oscillations, and in the third I will show how both these phenomena are made use of for purposes of wireless telephony.

Diagram 1 shows four different methods of using an arc for the reproduction of the human voice, or making it act as a loud-speaking telephone.

Simon discovered the phenomenon of the speaking arc in 1897, which he explains as follows:

"When the alternating currents of the microphone circuit are added to those of the continuous current circuit, the heat of the arc is increased in accordance with Joule's law, and the volume of the gases in the arc is correspondingly varied. These variations in volume set up sound waves in the air."

Simon has also shown that the arc can be used in the place of a microphone.

Diagram 2 shows Duddell's connections for the speaking arc which I am using for the experiment I am about to show you. This method was described by Duddell in 1900.

As you see from the diagram before you, between the arc and the D.C. supply are placed two chokes CC. The primary of an air core transformer T, is shunted across the arc in series with a condenser. The secondary of the

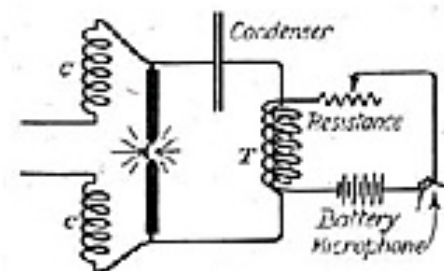

Fig. 2

transformer is connected in series with a battery and a microphone. I have obtained the best results by using 12 volts and adding suitable resistance to the circuit in order to obtain fine regulation.

*Paper read before the Wireless Society of London, at the Institute of Electrical Engineers, by G. G. Blake.

The condenser prevents the direct current from the mains from passing thru the transformer while it allows the alternating current from the transformer to pass. The two chokes have an exactly opposite action; they prevent the alternating current from passing away from the arc into the supply mains while they allow the direct current to pass.

Experiment 1.—Speaking Arc.

[At this point the experiment of the speaking arc was shown and the voice of a person speaking at the far end of an arc so that it could be clearly heard by a telephone line was reproduced by the everyone in the lecture hall.]

This phenomenon is far more complex than would appear upon first observation; not only are vibrations being set up in the air in the form of sound waves which we hear, but both the light and heat radiations are altering in intensity in exact accordance with the vibrations produced by the speaker's voice in the next room.

Slide 3 shows the speaking arc used as a photophonic transmitter in the place of Bell's original manometric flame. This method has been developed recently by Ruhmer, in Berlin. R is a concave

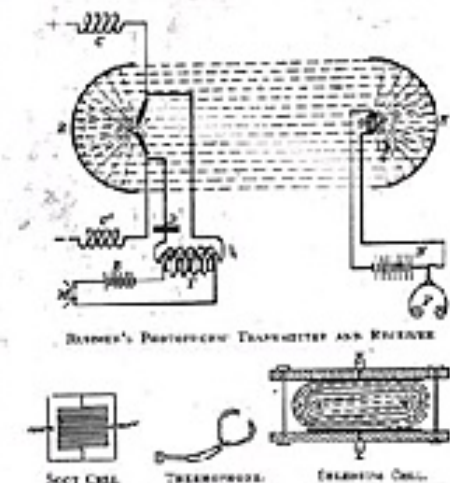

Fig. 3

mirror behind the speaking arc which projects a beam of light on to a similar mirror R. This in turn focusses the light on to a selenium cell S, which is connected in series with a telephone and battery B. Every variation of light intensity causes a variation in the amount of current passing thru the cell and phones, and so reproduces the voice. A soot cell may be used in place of selenium, but is of more interest than practical value, as the alterations of resistance in soot due to the action of light are much smaller than in the case of selenium.

In order to show that the voice may be conveyed by the heat radiations, a Bell's thermophone may be used. It consists of a short glass tube, ending in a small bulb of very thin glass, which contains a piece of charred cork. The arc is focussed on to the cork by means of a concave reflector or a lens, and the variations of heat intensity cause corresponding variations in the volume of the cork and the air surrounding it, which are heard as sound.

The Thermophone.

This is a home made thermophone which I have found to answer very well for this purpose. A thermopile and telephone may be used in place of a thermophone; in which case the heat variations produce varying current thru the phones and reproduce the voice.

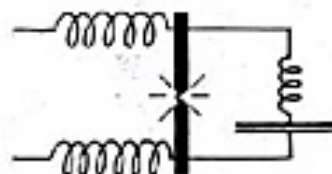

Fig. 4

PART II.

We now come to the second part of my lecture, the use of the arc as a generator of high frequency alternating currents. Slide 4 shows the connections for the musical arc. The phenomenon was probably first observed by Lecher, but has since been thoroughly investigated by Duddell. The connections are very similar to those already shown for the speaking arc. The arc is fed thru two chokes and shunted with a circuit containing an inductance and condenser. When working under these conditions the arc emits a pure musical note.

Its action is accounted for as follows: When the arc is struck, the condenser charges, then it discharges itself across the arc; and owing to the inertia of the circuit it does not come to rest at once, but over-discharges; reversing the polarity of the charges on each of its coatings; the condenser then again discharges across the arc and is reinforced by the supply current, so that practically no damping takes place, and the process is repeated as long as the arc is maintained.

The rate of the oscillation depends approximately on the inductance and capacity of the shunt circuit. The limit of frequency of the oscillations obtainable by means of a musical arc in air is somewhere about 30,000; therefore, although the great importance of the singing arc was appreciated by many workers, it was not until 1902, when Valdemar Poulsen discovered a method of increasing the frequency by placing the musical arc in an atmosphere of hydrogen, that the arc method became applicable to wireless telephony.

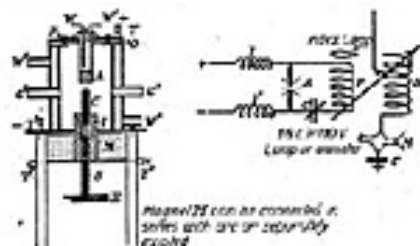

Fig. 5

Experiment 2.—Musical Arc.

The musical arc was then shown and a tune was played by altering the amount of inductance in the shunt or oscillatory circuit.

Before showing the hydrogen arc in action, several oscillograms were shown, illustrating the necessity for using ex-

tremely high frequencies for wireless telephony.

One slide depicted the oscillations produced in the aerial circuit of the lecturer's station at Richmond, by means of a sim-

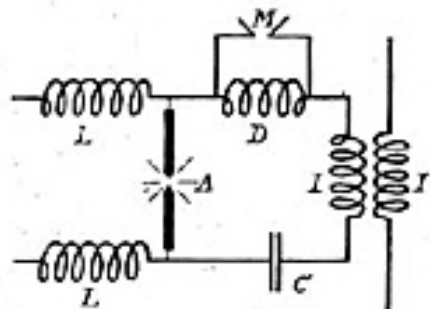

Fig. 6

ple Marconi transmitter, consisting of a closed primary circuit, containing a fixed spark-gap in series with a condenser and an inductance, coupled inductively to an open aerial circuit.

This oscillogram was taken with the transmitting key held down (to the great delight of other stations in the neighborhood). The current was supplied from an induction coil fitted with a "Sanax" mercury break giving about 100 interruptions per second, so that in this case every 1-100th of a second we give rise to a series of oscillations whose frequency depends on the wave-lengths to which the station is tuned; in this case I used a 300-metre wave, giving a frequency of 100,000. This frequency would be quite high enough for wireless telephony were it undamped, but, unfortunately, for each break we only obtain about 20 or 30 of these oscillations at most, and diminishing in amplitude as they die out. Then follows a period of rest several hundred times as long as the time taken by the oscillations themselves. I think the impossibility of transmitting speech by this spark method is fairly obvious. The frequency of the sound waves produced by the human voice amounts, for high notes, to several thousand per second, and it stands to reason that such frequencies cannot be continuously transmitted by groups of waves having intervals as long as 1-100th of a second between each.

The first oscillogram was taken under similar conditions, but using a 220-volt direct current arc in hydrogen in place of a spark-gap. In this case the oscillations follow each other so rapidly (the frequency being about 300,000 per second) that they cannot be distinguished

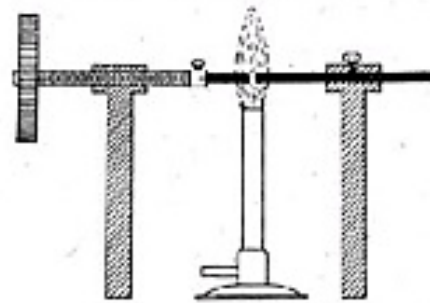

Fig. 7

individually. The waves are practically undamped, as the damping caused by the oscillating circuits is compensated for by the supply current.

Let us again consider the analogy of the swing of a pendulum. The swing receives in this case a very great number of little pushes, each exactly in time with its oscillations, so that at the end

of each complete swing it receives sufficient energy to compensate for the loss due to damping, and so the amplitude of the oscillations of the swing remains constant. These undamped waves are inaudible when listened for on an ordinary crystal or magnetic detector, and are quite suitable for wireless telephony.

Slide 5 is a diagram of the arc I used for this experiment. The diagram on the right hand side shows the connections I am using for wireless telephony (pilot lamp, tuning lamp, etc.). Magnet M is to revolve the arc. In Slide 6, instead of placing the microphone in the aerial circuit, as shown in the last slide, I have placed it across a few turns of the inductance, as suggested by Campos, and found it to work quite satisfactorily.

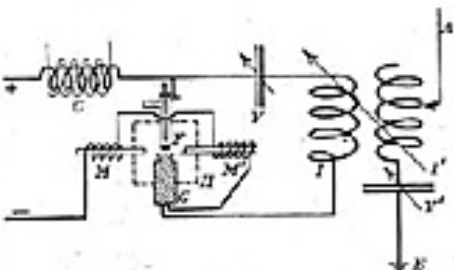

Fig. 8

Fessenden says, in a paper that he delivered before the American Institute of Electrical Engineers in 1908:

"As a matter of fact the transmitter can be placed almost anywhere, in the circuit between the arc or dynamo and the antenna, or between the arc or dynamo and ground, or in the transformer circuit, or in shunt to an inductance or capacity; the results obtained in all cases being indistinguishable. The sole criterion of success seems to be that the transmitter should be capable of handling the energy, and the circuit should be properly adjusted. Some success has

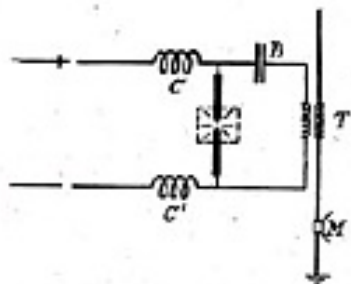

Fig. 9

been attained by placing the transmitter in the field of the dynamo, but this method requires very careful design of the field circuit." This is known as the trigger control alternator scheme.

I have fitted up a short aerial in this room, and at the close of the lecture I propose for just a quarter of an hour, and no longer, to give you a demonstration of wireless telephony. A gramophone will be allowed to play in this room and the music will be transmitted wirelessly to an adjoining room, where it will be heard by a pair of 'phones in the ordinary way. If time permits, we will also transmit speech from this room to the receiving instruments. At Slide 7 is shown a simple form of arc generator, invented, I believe, by De Forest; which I have used successfully for wireless telephonic transmission. The two great objections to this method were: that it would only work with small currents, and that the carbons required very

frequent adjustment owing to their rapid burning away. The arc here burns in a Bunsen gas flame.

One of the first difficulties that was encountered when using the hydrogen arc as a H. F. generator was the fact

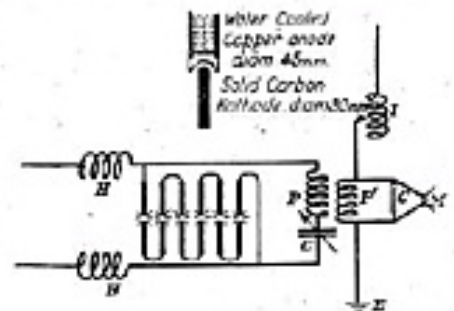

Fig. 10

that for any particular voltage and form of lamp, there is a critical amperage above which the arc becomes thoroughly unstable, and will no longer produce oscillations.

Poulsen has succeeded in overcoming this difficulty—firstly, by water-cooling the positive electrode, which increases the critical value from about 4 to 5 amps. He found also that he could greatly increase this critical current value by the use of a powerful magnetic field at right angles to his arc, as shown in Fig. 8; and when it is necessary to deal with larger currents still, he connects up several arcs in hydrogen in series.

Fleming, Ruhmer and others have pointed out that in this case, we are in the presence of a new phenomenon. The arc is producing forced oscillations in its shunt circuit; it is creating a tremendous number of separate and rapidly damped oscillations, which follow each other so rapidly that they were at first mistaken for one continuous undamped oscillation.

The magnet is arranged in series with the arc so that its blast is in phase with the oscillations; the arc being thereby momentarily extinguished between each oscillation.

With regard to the principles involved in this arc generator, it is interesting to note the following:

(1) That in 1892 Elihu Thompson suggested the use of a magnetic blast at right angles to the spark gap of his H. F. generator, for which he took out patents at that date.

(2) That Poulsen makes no mention of the use of a magnetic blast in his earlier patents. He first mentions it in 1903.

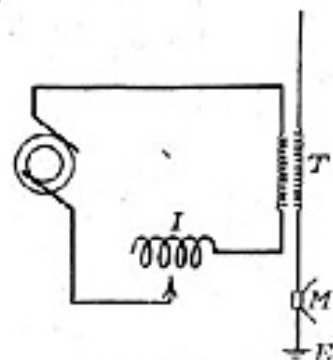

Fig. 11

(3) That in 1903 Ruhmer invented an arc interrupter for induction coils, on the same principle; but in this case the arc burns in air.

(To be continued in the May issue.)

HOW-TO-MAKE-IT DEPARTMENT

This department will award the following monthly prizes: FIRST PRIZE \$3.00; SECOND PRIZE \$2.00; THIRD PRIZE, \$1.00. The idea of this department is to accomplish new things with old apparatus or old material, and for the most useful, practical and original Men submitted to the Editors of this department, a monthly series of prizes will be awarded. For the best ideas submitted a prize of \$5.00 will be given; for the second best idea a \$2.00 prize, and for the third best a prize of \$1.00. The article need not be very elaborate, and rough sketches are sufficient. We will make the mechanical drawings.

FIRST PRIZE \$3.00.

A HOME-MADE LAMP DIMMER.

Below is a drawing of a home-made lamp regulator which I am using with a 60-watt lamp successfully.

The material required: 1 lamp or fuse base; two 1 1/4" fibre discs 1/4" thick; one 1 1/2" fibre disc 1/4" thick; No. 25, 26 or 27 gauge German silver wire; 1 socket; two 1" fibre or hard rubber discs; 6 small wood screws; 8 screws and 9 nuts off old dry batteries; 1 sheet metal cylinder perforated as shown.

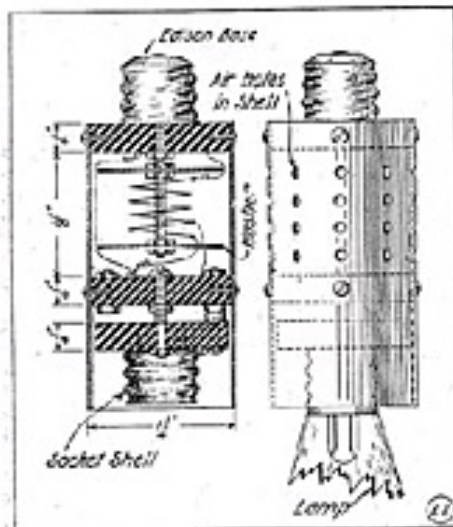

Solder the cylinder so it fits over the 1 1/4" discs neatly. Screw one of the 1 1/4" discs to a lamp base of a broken bulb. Drill four 1/8" holes in the other 1/4" discs. More holes may be drilled if the builder so desires, thereby obtaining a larger range of regulation. The piece of copper that holds the bulb in a lamp socket should be removed and screwed to the smallest disc as shown. The core which is to hold the resistance wire is made from a screw off a dry battery, the washers being made of cardboard or mica.

All metal on the core should be well insulated. After you have a few layers wound on the core, connect the wire on the inside of the coil to a lamp which is connected to a circuit. Complete the circuit by piercing the insulation on the top layer of the coil with a needle which is attached to the circuit, and you can thus tell when you have the resistance you want without harming the insulation. The connections are made as shown. The different brilliancies can be had by turning the bulb. About 200 feet of No. 27 18% German silver wire is required in all for most requirements.

Contributed by
RALPH HITESHEW.

Albert Baxendale, of Indianola, Iowa, says in a recent letter:
"I think yours is the best Electrical paper that is published for the money. 'The Constructor,' 'How to Make It Department,' and the 'Question Box,' are very good features. 'The Experimental Electricity Course' is the best thing in your magazine."

SECOND PRIZE \$2.00.

TIKKER FOR UNDAMPED WAVES.

During a recent Western trip, the writer was allowed to "listen in" on a set equipped with a Poulsen Ticker, and it certainly was a treat to hear the station at South San Francisco sending its messages out into the ether.

He was also told that this station was quite powerful and operated on wave lengths of 5,000 and 7,000 metres during night and day respectively. Consequently, provisions must be made to tune in such long waves.

To build the tikker, the brass disc in the diagram should be mounted on, and insulated from, the shaft of preferably an A. C. induction motor. Having done this, the motor is started, and with the edge of a file a groove is cut in the edge of the disc. This groove should be left rough by the file and not polished in any way. The brass wires touching in the groove should be short enough to avoid any excess vibrating, and must only press hard enough to make steady contact.

To eliminate the noise from the operating room, the whole instrument was placed in a felt-lined box.

Since extremely fine tuning is required, a condenser is placed from aerial

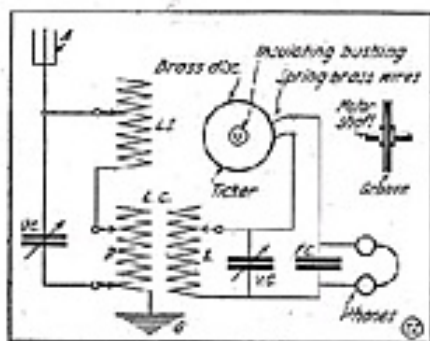

to ground as per diagram, also very loose coupling between the primary and secondary of the loose coupler is required.

By **JAMES L. GREEN.**

ON EFFICIENT AERIAL INSULATORS.

The aerial insulation is one of the first and most important things which the beginner in wireless encounters. Not only the beginner but also the old hands are given anxiety at times. To properly insulate the aerial costs money, of

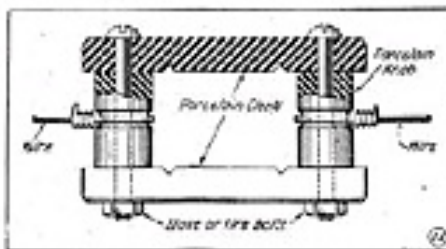

which the amateur usually has very little, which he does not want to use in some other way.

THIRD PRIZE \$1.00.

A CALIBRATED SPARK GAP.

A calibrated spark gap is useful in making spark voltage measurements. Make up an ordinary spark gap as per cut, but in one upright tap the hole for an 8-32 rod as shown at C.

The idea of this gap is for experimental purposes for accurately measuring the spark. While measuring the length of any spark coil, needles are put in at X, because a spark coil's rating is always measured between needle points.

The principle involved in this gap is similar to that used in micrometers,

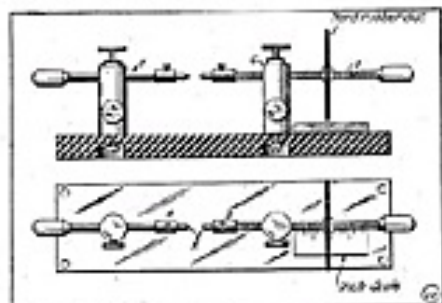

namely, that one complete turn of rod D away from E gives 1/32"; while half a turn gives 1/64", et cetera.

The hard rubber or other disc as shown indicates directly the length of the gap between needle points, as it moves along the scale on the base, divided in inch dimensions and fractions thereof. The base should, of course, be made of hard rubber or marble to give freedom from leakage which would create a considerable error in the final results. Consult any text-book for spark values or refer to September, 1914, issue of this paper.

Contributed by
ALBERT C. SHAW.

Porcelain cleats are often used; in fact, a majority of the amateur stations are equipped with them. Several of these cleats are often used in series to increase the insulation, but this shortens the aerial. However, this is not the main objection to them. The objection is that the amateur usually has to put up a new aerial after a storm, on account of the weakness of the porcelain. If two or three are used in parallel, this objection is decreased somewhat.

An excellent aerial insulator, however, can be made with porcelain cleats and knobs, after the pattern of the strain insulators; two of each of the cleats and knobs and two stove or tire bolts are needed for each insulator. The bolts are well smeared with tar or asphaltum paint to prevent them from rusting and eventually breaking. The construction of the insulator is easily seen from the sketch, and should not cost more than six or eight cents, which is about half the cost of insulators manufactured for aerial insulation. This insulator should therefore solve the problem which confronts most amateurs.

Contributed by
FRANK H. BROOME.

A BOY SCOUT SIGNAL LAMP.

An interesting signal apparatus for Boy Scouts and others can be easily constructed with an E. I. Co. bicycle lamp No. 6710, and a No. 1118 key. It is mounted on a stand. To start the construction of the apparatus, we begin with the stand.

Three pieces of wood, 3 or 4 feet long, 1 inch wide and 1 inch thick, are obtained.

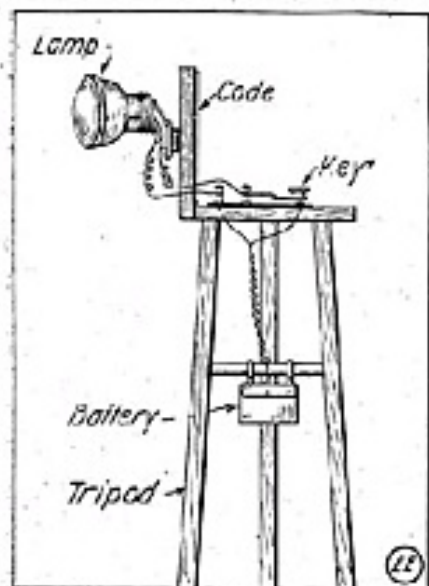

These are fastened to a piece of wood 4 inches long, 3 inches wide and 1 inch thick, held together by a mortise joint. On the top of this base a piece of wood 5 inches long, 1 inch wide and 1 inch thick is fastened upright by a brass screw. The lamp is fastened on to this strip, and the key is fastened on the base. Between two of the legs a piece of dowl pin is fastened, on which the batteries are strapped. A copy of the code is pasted on the back of the upright strip. One wire runs from the battery to the lamp, another from the battery to the key, and also a camera tripod of the compact folding type is very adaptable.

The Morse telegraph code is readily employed with this signal lamp, consisting of short and long flashes, and on a clear night signals can be flashed for comparatively long distances. It can be used as a signal from one house to another, etc., ad lib.

Contributed by SAMUEL RUBEN.

HOW TO CONSTRUCT A RADIATION INDICATOR.

The following method of using a Geissler tube to test the radiation of an aerial is more simple and satisfactory

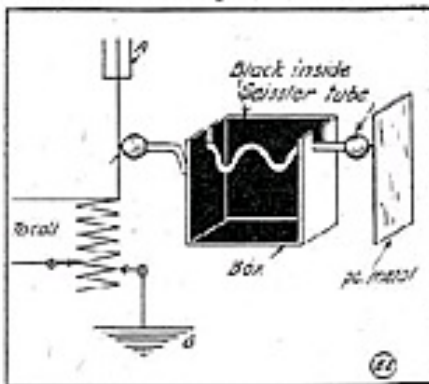

than the usual arrangement of connecting it in series with the aerial circuit, which is wasteful.

This radiation indicator has been used in my wireless station with entire satisfaction.

If one electrode of a Geissler tube (these cost about 25 to 35 cents) be touched to a charged aerial and the other electrode left unconnected, the tube will be lighted with an intensity proportional to the difference of potential between its two terminals. I mounted the tube in an uncovered cardboard box blackened on the interior, which better enables the observer to judge the light intensity in the tube.

Contributed by CHAS. ROSENTHAL.

AN ELECTRIC READING LAMP.

After having the house wired for electric lights some time ago, I decided I wanted a stand lamp to read by, as the chandelier was too high to read by.

So I made an electric stand lamp out of our old kerosene lamp, as follows.

By examining our lamp, I discovered there was a hollow brass tube running clear thru the center of the lamp, where the flame got its draft.

So I got a piece of fibre 3/4 in. thick and cut out a round piece that would fit this tube tightly, as in Fig. 2. Next I took from an old receptacle the brass shell shown in Fig. 2, and fastened it to the fibre piece by two small bolts passed thru the lugs in the shell, then thru two holes in the fibre piece, and then screwed nuts on the other end. The center contact for

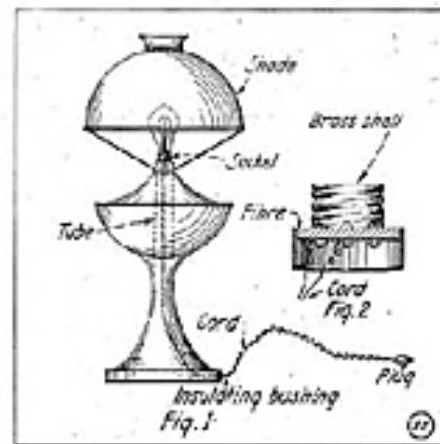

the lamp is an 8-32 bolt, passed thru a hole in the center of the fibre piece and drawn up tight with a nut, on the bottom.

Next buy about 8 or 10 feet of flexible cord and connect it to your receptacle as shown. Now run the cord down thru the center of the lamp, thru the insulating bushing in the bottom of the lamp, and attach it to an attachment plug. Next force the socket into the top of the draft tube of the lamp, screw a tungsten bulb in, put the shade in the lamp, and you will have as serviceable a stand lamp as you could wish. For 110-volt service, a regular Edison key or chain pull socket is easily fastened in place on a piece of fibre or on a piece of brass pipe, fitted with a lock nut at the bottom of the lamp. Contributed by

GLEN DECKER.

A CLEVER MINERAL DETECTOR.

Of all the instruments in the average amateur's set, the mineral detector probably requires the most careful and skillful attention. However, this disadvantage is offset by the sensitiveness of galena, silicon and the other minerals.

In most responders, the contact point is perpendicular to the crystal, but the writer has found that if both the mineral and contact wire are horizontal, the adjustment is maintained better and the detector remains just as sensitive, if not more so, than before.

A detector which utilizes this scheme is shown in Figs. 1 and 2. It will be noticed that both the crystal and "cat-whisker" can be moved either vertically or horizontally and that this is obtained

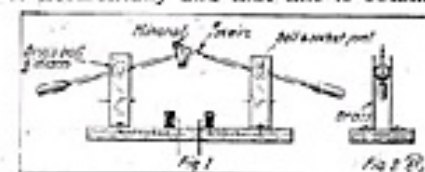

by the use of a simple ball and socket joint. The base is 6 inches long and 3 inches wide and may be of hard rubber or fibre. The ball and socket joint is easily made in the following manner: Procure a brass ball 3/4 in diameter and bore a 1/4 in hole thru it. Into this hole place a 3 in brass rod, soldering same in the brass ball. An Electrite knob is placed on one end and a "cat-whisker" on the other. The latter may be a No. 36 copper wire. Construct another ball and rod in the same manner, substituting a small mineral cup for the "cat-whisker." The mineral is held in this cup by Hagenium alloy. Four uprights made of brass strip are used to support the balls. They should be 2 3/4 in long and 1 in wide.

Referring to Fig. 2, it will be noticed that at the top of each brass upright is a small indentation. The brass ball is held here by spring action. The balls should be gripped tight enough to prevent their falling out but at the same time they should be able to be moved easily. This position will soon be found by experiment.

When using galena with this detector, the "cat-whisker" is employed. With silicon, sharpen the brass rod to a point.

Contributed by IRVING BYRNES.

A NEW ELECTRICAL GROUND.

High tension switch operating mechanisms are grounded; transformer shells are grounded; machine frames are grounded; wireless apparatus is grounded, but where's the efficiency unless the grounding system terminates itself in a ground that is perfect? say the sponsors of the new "Maxim" ground box.

This ground box and the 500 square inches of close contact grounding surface, the special high-efficiency, moisture-attracting hygroscopic compound with which the box is filled, the extra heavy coat of gal-

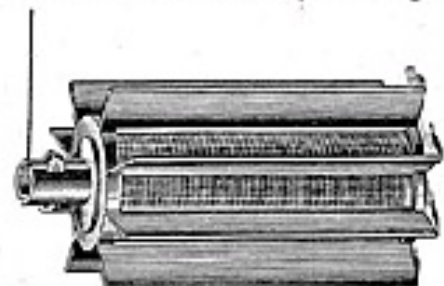

vanzing—all serve to render it a ground of permanent efficiency. It is a useful and efficient "earth" for radio-telegraphic stations, where no natural earth connection is available, such as water pipes.

We want to buy May, '13, Oct., '13, and Jan., '14, copies "E. E." Address the Editor.

WRINKLES—RECIPES—FORMULAS

Edited by S. GERNSBACK

Under this heading we will publish every month useful information in Mechanics, Electricity and Chemistry. We shall be pleased, of course, to have our readers send us any recipes, formulas, wrinkles, new ideas, etc., useful to the experimenter, which will be duly paid for, upon publication, if acceptable.

FORMULA NO. 8.

Etching for Metals.

(1) *Brass Sign*—Paint sign with asphalt varnish, leaving the parts to be etched unpainted. Raise a border around the outside, made of soft beeswax. Take 1 part of Nitric Acid diluted in 5 parts of Water. Pour this solution on to the sign about $\frac{1}{4}$ inch deep. When the letters are etched deep enough, pour acid off, clean plate by heating and wiping with turpentine.

(2) *Copper Etching*—1 part of Nitric or Sulphuric Acid; 2 parts of Potassium Bichromate (Saturated solution); 5 parts of Water.

(3) *Etching on Cutlery*—Take 1 part of Asphaltum; 1 part of Burgundy Pitch; 1 part of Beeswax. Melt together and mix. Warm the piece of cutlery, take a ball of cotton and smear a small quantity of the above wax on the blade, evenly all over the surface. When cold, scratch the required design or name on the article and touch the parts with a solution of one part of Nitric Acid in five parts of Water, using a camel's hair brush.

After a few minutes dip in hot water and wipe the blade with benzine.

(4) *Etching on Glass*—Mix together in a receptacle of lead: 3 parts of Sulphate of Barium; 1 part of Fluoride of Ammonium with Sulphuric Acid sufficient to bring the mixture to the consistency of rich milk. Cover the glass with a small quantity of hot beeswax. To etch proceed as for cutlery.

(5) *Etching on Silver*—Same as copper or brass.

(6) *Etching on Bronze*—100 parts of pure Nitric Acid at 40°; 5 parts of Muriatic Acid at 20°.

(7) *Etching on Brass*—Take 60 parts of Nitric Acid at 40°; 160 parts of Water. Dissolve 6 parts of Potassium Chlorate in 100 parts of Water. Mix the two solutions together.

(8) *Etching on Steel*—62 parts of Nitric Acid; 125 parts of Water; 187 parts of Alcohol; 8 parts of Copper Nitrate.

(9) *Zincographic Etching*—2 parts of Sulphate of Copper; 3 parts of Chloride of Copper; 64 parts of Water; 8 parts of Muriatic Acid.

(10) *Different Grounds for Etching*—(a) 30 parts White Wax; 30 parts Gum Mastic; 15 parts Asphaltum. (b) 3 parts White Wax; 1 part Black Pitch; 4 parts Asphaltum; 1 part Rosin. (c) 4 oz. soft Linseed Oil; $\frac{1}{2}$ oz. Gum Benzoin; $\frac{1}{2}$ oz. White Wax. Boil together. S. G.

ELECTRICAL HAND-SHAKING.

Electrical experimenters are, as a class, just as mischievous and in most cases more so, than the average boy, besides having the advantage of being able to call the electrical medium to his aid.

I have constructed the following apparatus that has given me more fun than anything I ever had. Imagine yourself meeting a friend on the street, going up and shaking hands with him and suddenly getting a shock that takes the breath away from you. What would you be liable to do? You don't know till it

IRON PIPE MAST BASE INSULATOR.

The diagram shows the method which I am using to insulate a pipe mast from the ground. It is made from an old glass telegraph insulator and a piece of

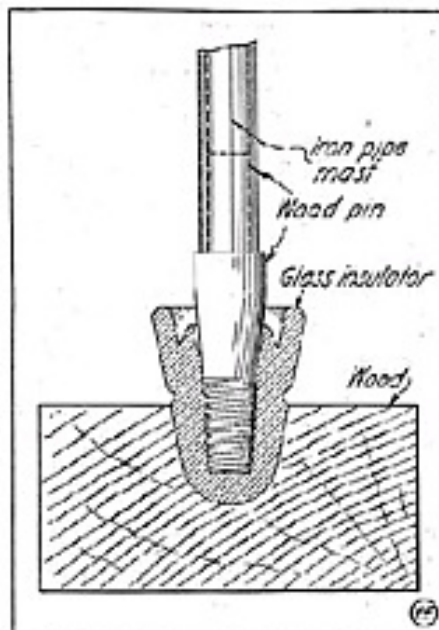

wood driven up the lower end of the pipe and trimmed to fit the insulator. The insulator rests on a block of wood (cypress, etc.), with a hole bored in the top to fit the insulator.

Submitted by

WATSON McALEXANDER.

happens, but you can find out what the other fellow will do, by making one of these electrical greeters.

Purchase a medical coil and a 3-cell flashlight battery. Lay the battery on the base of the coil and fasten it there with friction tape. Connect one pole of the battery to one of the primary binding posts; run a wire from the other pole of the battery and a wire from the remaining binding post. Twist these two wires together and fasten their ends to a push button. Make these wires long enough so they will reach from your back trouser pocket up under your coat and down your sleeve and extend about three inches beyond the end of the sleeve. When the button is pushed, the coil will operate.

A wire is then connected to each of the secondary binding posts; one reaches down the trouser leg to a heel plate on the shoe and the other up under the coat and down the right hand sleeve to a ring on the finger. The wire is soldered to the ring, while the inside of the ring is insulated with a piece of paraffin paper glued in place.

Lay aside the handles that are supplied with the coil and also remove the regulating tube to get the full force of the current.

Now you can test it on your sister or some other person, but don't expect to get away unscathed yourself, as you may get quite a shock. However, you have the advantage in knowing it is coming, while the victim is more taken back by surprise than the shock itself.

You can put the coil in a small wood or cardboard box to protect it while in your pocket.

Submitted by

THOS. W. BENSON.

ELECTRICITY TO DRIVE WARSHIP.

The American super-dreadnought California, one of the three huge new ships just ordered, will be driven by electric motors. Secretary Daniels authorized this type of power plant for the big fighter on recommendation of Rear-Admiral R. S. Griffin, Engineer-in-Chief of the Navy.

If it proves as great a success in the battleship as it has in the naval collier Jupiter, Navy officers foresee the complete displacement of direct steam drive in future American warships.

The California, which will be built in the New York Navy Yard, will be the first electrically driven warship built. The decision to install the new system aboard the battleship was arrived at after exhaustive study of the performance of the Jupiter.

The reason for this form of drive is due to the high efficiency and extreme flexibility of the control features when electricity is employed. Steam valves and pipes are forever needing replaced packing, reseating, etc., and it is very difficult to control steam valves mechanically at anything like the speed of control possible by electrical means.

ELECTRIC LIGHTS FOR BUGGIES.

Those who drive at night have often undoubtedly wished for electric lights to take the place of the usual lantern hung beneath the buggy or the oil side lamps fitted on same. It is the practice now to equip the better class of pleasure vehicles, such as these, with a storage battery and one or two side lamps; also a tail lamp. The application of the lamps, which may be 6-volt 6 C. P. Tungsten type, together with 6-volt, 60-ampere-hour storage battery, is depicted in the cut here shown. Such a battery will light three 5-volt 6 C. P. Tungsten lamps for about 20 hours steadily or altogether on one charge, or one headlamp and tail lamp for a period of about 30 hours total. The batteries are readily

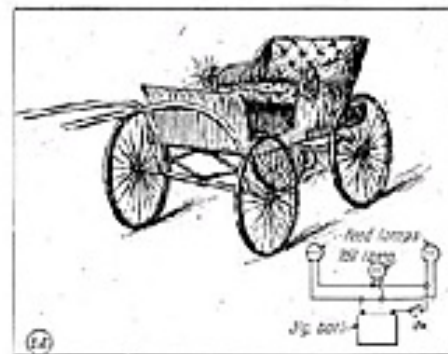

recharged at any automobile garage or electrical shop at a small charge. The whole outfit, including lamp cord No. 16, reflectors, if necessary, lamps, sockets and battery, may be purchased of any electrical house and they will not cost altogether more than ten or twelve dollars.

H. Voltman of Buffalo, N. Y., writes us:

"I received the second number of the 'Electrical Experimenter' recently. I like the magazine very well and I think it is well worth the price I paid for it."



THE ACTION OF LIGHT ON SELENIUM.

There has been some uncertainty in the past as to the seat of light action in selenium, but Messrs. Brown and Sieg have succeeded in producing several forms of large crystals of metallic selenium, which have enabled them to determine several interesting facts concerning the seat of light action in selenium, says the "Electrical World," in a review of the Philosophical Magazine for Oct., 1914. The authors describe various observations which have led to the following results: The change of resistance by light is a property of the crystal and not an action taking place at the contacts. Illumination of different points along the crystal produces approximately the same effect at all places. The crystal is changed in conductance by approximately the same amount whether the illumination is on the side of the contacts or on the opposite side. From these results the authors draw the general conclusion that the light acts throughout the crystal and that the conductivity is almost uniform throughout the crystal. They then refer to evidence deduced from the law of superposition of intensities. They used two lamps in certain combinations and found that the two lamps acting together produce almost identically the same effect whether they act on the same side or on opposite sides. Moreover, there is an apparent spreading of light action. The authors produce evidence to the effect that the action of light in crystal is transmitted to a distance. There seems to be a new "action at a distance." If the rate of transmission of the action through the crystal can be determined, certain information may be obtained as to the nature of the mechanism of transmission. The possible processes that are suggested are electronic transmission such as exists in the flow of the electric current, transmission by the elastic vibration of the medium, and possibly by the interaction of parts of the atoms moving with velocities approaching that of light.

A THERMOCOUPLE ELECTRIC GENERATOR.

A new method of generating electricity on a commercial scale by thermo-electric couples has been devised by Mr. J. Marshall, of Dresden, Germany. In general, the apparatus consists of connected thermo-electric couples arranged around and touching the periphery of a flue carrying heated gases, says the "Electrical World." The unheated ends of the couples are cooled by circulating cold air around them. Tests on the apparatus conducted by Dr. Kollert, professor in the technical schools at Chemnitz, Germany, are said to show that, with a temperature of 369°C. at the hot junction of the couples and 55°C. at the cold ends (making a difference of 313°C.), the open-circuit E.M.F. produced in a single couple was 0.077 volt. The couples consist of two elements, one a casting made of special alloy, the composition of which is kept secret, the other a plate of copper-nickel alloy. The two elements are separated by a sheet of mica or asbestos, and at the place where the heat is applied are joined by an electrolytically deposited band of copper. Five of these couples are connected rigidly together in series, forming a unit.

(Continued on page 238.)

HIGH VOLTAGE SHOCKS AND HOW TO TREAT THEM.

Rules Recommended by Resuscitation Committee.

Following are the rules which have been recommended by the Commission on Resuscitation from Electric Shock



representing the American Medical Association, the National Electric Light Association and the American Institute of Electrical Engineers:

FOLLOW THESE INSTRUCTIONS EVEN IF VICTIM APPEARS DEAD.

I. Immediately Break the Circuit.

With a single quick motion, free the victim from the current. Use any dry non-conductor (clothing, rope, board) to move either the victim or the wire. Beware of using metal or any moist material. While freeing the victim from the live conductor, have every effort made to shut off the current quickly.

II. Instantly Attend to the Victim's Breathing.

1. As soon as the victim is clear of the conductor, rapidly feel with your finger in his mouth and throat and remove any foreign body (tobacco, false teeth, etc.). Then begin artificial respiration at once. Do not stop to loosen the victim's clothing now; every moment of delay is serious. Proceed as follows:

(a) Lay the subject on his belly, with arms extended as straight forward as possible and with face to one side, so that nose and mouth are free for breathing (see Fig. 1). Let assistant draw forward the subject's tongue.

(b) Kneel straddling the subject's thighs, and facing his head; rest the palms of your hands on the loins (on the muscles of the small of the back), with fingers spread over the lowest ribs, as in Fig. 1.

(c) With arms held straight, swing forward slowly so that the weight of your body is gradually, but not violently, brought to bear upon the subject (see Fig. 2). This act should take from two to three seconds. Immediately swing backward so as to remove the pressure, thus returning to the position shown in Fig. 1.

(d) Repeat deliberately twelve to fifteen times a minute the swinging forward and backward—a complete respiration in four or five seconds.

(e) As soon as this artificial respira-

tion has been started, and while it is being continued, an assistant should loosen any tight clothing about the subject's neck, chest or waist.

2. Continue the artificial respiration (if necessary, at least an hour), without interruption, until natural breathing is restored, or until a physician arrives. If natural breathing stops after being restored, use artificial respiration again.

3. Do not give any liquid by mouth until the subject is fully conscious.

4. Give the subject fresh air, but keep him warm.

III. Send for Nearest Doctor as Soon as Accident is Discovered.

1. Keep a list of doctors posted in high voltage plants or laboratories.



Below is seen the famous "Pulmotor" used for reviving unconscious victims.



Key to Illustration:
 C = Oxygen Cylinder.
 V = Control Valve.
 D = Reducing Valve.
 U = Reversing Lever.
 S = Injector.
 L = Reversing Chamber.
 H = Hand Bracing Lever.
 B = Accordion Bellows.
 F = Inflated Air Tube.
 A = Exhausted Air Tube.
 M = Mask.
 Q = Head Ring.
 W, W' = Two Tightening Straps.
 T = Taper.
 Z = Triage Pouches.
 G = Flexible Metal Tube for Intake or.
 R = Isolation Mask.
 I = Resuscitant Bag.
 P = Extension Tube for connecting with a large Oxygen Cylinder outside the case.

INDUCTION BALANCE LOCATES BULLETS.

The announcement that the Hughes induction balance is being used to locate bullets in the wounded victims of the war, says *Engineering*, London, recalls the fact that this instrument was first employed for this purpose when President Garfield was shot by Guiteau. With an induction balance, improvised on Hughes' directions, the position of the bullet in the President's body

(Continued on page 238.)

LATEST PATENTS

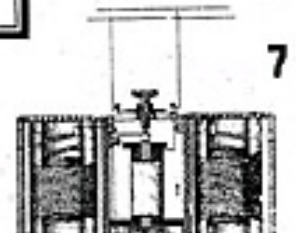
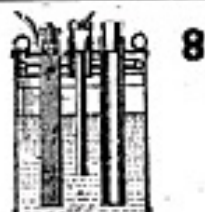
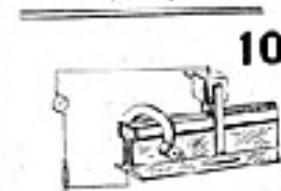
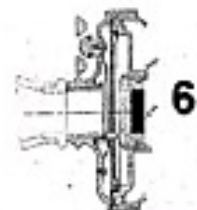
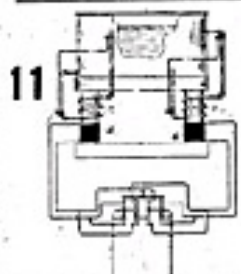
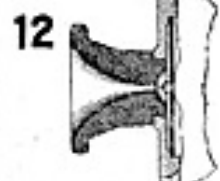
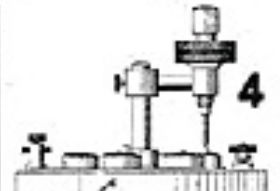
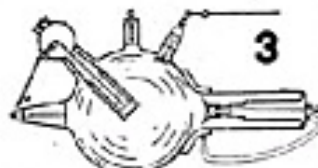
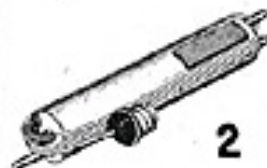
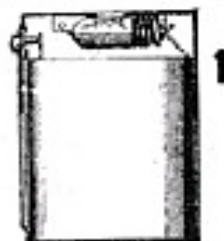

ELECTRIC FLASHLIGHT (Fig. 1)—A new flashlight design having the bulb placed cross-wise.

HIGH FREQUENCY MACHINE (Fig. 2)—Kidder's patent hand type machine. Very small. Works on 110 volts A. C. or D. C.

X-RAY TUBE COOLING (Fig. 3)—Accomplished by causing a stream of gas to circulate through cathode.

RADIO DETECTOR (Fig. 4)—Has radially movable arm, allowing point to be used on any of several cups.

MULTIPLE FUSE PLUG (Fig. 5)—Arranged to instantly renew fuse by simply turning upper switch portion.

MICROPHONE (Fig. 6)—Novel construction in which the resistance material is under compression while not talking, and vice versa.

OZONATOR (Fig. 7)—Employing a vibrator and step-up coil for use on 110-volt D. C. circuits.

PRIMARY BATTERY (Fig. 8)—A new battery having liquid electrolyte, gas vents, etc., so it can be sealed.

RECEIVER HEAD-BAND (Fig. 9)—Design with sliding rods, supporting receivers, as well as acting in any direction.

ELECTRICAL PRODUCTION OF RAILS (Fig. 10)—Increasing life of rails by electrical welding or melting a steel alloy on them.

ELECTRIC HEATER (Fig. 11)—Novel heater having water circulation plus forming secondary of transformers at 2, 3.

MOUTHPIECE (Fig. 12)—Improved telephone mouthpiece of malleable composition with inner curved parts shaped to propagate sound waves in most efficient manner toward diaphragm.

ELECTRICAL HAND WARMER FOR MOTORISTS.

Now comes the electrically heated leather-covered grip for use on steering wheels of automobiles as developed by the Interstate Electric Company, New

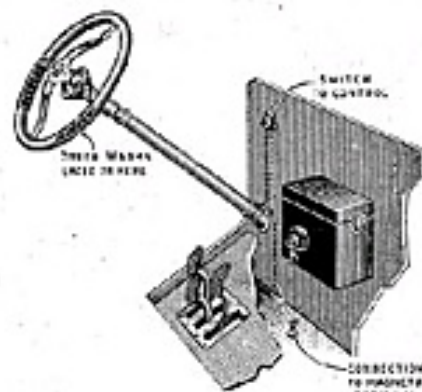

Orleans, La. The leather-covered grips are easily attached to the steering wheel as shown in the accompanying illustration, and are provided with laces for making them tight. Energy may be obtained from the storage battery of the car or, if the magneto's rating is high

A "SHOCK-PROOF" KEY FOR POLICEMEN.

A new key has just been placed on the market which is a simple invention aiming to protect the policeman from an electrical shock when sending in his duty call over police patrol boxes. The key with which he opens the patrol box is consequently made of a special composition which is as hard as metal but possessing excellent insulating properties. The key has a shoulder in the center which prevents the hand from coming in contact with the metal of the box.



It has been stated that a large majority of the electrical patents taken out are not practical. Be sure your invention is feasible; then go ahead.

Electricity is used to dry grain before grinding in certain European mills.

enough, from the magneto. A convenient switch controls the circuit so the heat can be turned off when not wanted. A high resistance wire unit is woven into the grips and covered over so that the hand does not make contact with wire itself. It requires only a small amount of energy.

HAVE YOU AN IDEA?

Are you using a new device or an improved modification of such, in your wireless or electrical laboratory? If so, why not write it up and send to us with a photo or sketch? Drawings invariably have to be made over by our draughtsman, and just so you express your ideas concretely and as briefly as possible, we are always glad to publish them, when the article possesses merit. Look over this issue carefully, re-read the articles twice, and you will soon pick up the knack of writing articles, and moreover, we pay you well for your efforts. Why not get busy to-day and get in the swim? Be a live, wide-awake Electrical Experimenter! Boost your paper and boost yourself. It's very easy!

Make all sketches on separate sheets of paper, and write only on one side of your text sheets. Send all contributions to "Editor," The Electrical Experimenter, 233 Fulton St., New York City.

Norman Otto, of Oshkosh, Wis., writes us:

"I have just received my fourth copy of the 'Electrical Experimenter,' and I want to say, it is and was the best magazine I ever read."



AMONG THE AMATEURS



Our Amateur Radio Station Contest is open to all readers, whether subscribers or not. The photos are judged for best arrangement and efficiency of the apparatus. To increase the interest of this department we make it a rule not to publish photos of stations unaccompanied by that of the owner. Dark photos preferred to light-toned ones. We pay each month \$1.00 prize for the best photo. Make your description brief. Address the Editor.

AMATEUR RADIO STATION CONTEST.

Monthly Prize, \$3.00.

This month's prize winner.

BEOGSTROM STATION.

Am glad to see you are having a wireless contest in your valuable magazine. As I am a constant reader of it, I have enclosed a picture and description of my radio station, so I may be able, possibly, to see it in the magazine. My aerial is 50 feet long, composed of six strands of wire with six lead-ins. The station is equipped with two complete receiving sets and one sending. A loose-coupler, double slide tuning coil, loading coil and one "Universal" detector stand and



Above: Mr. Beogstrom receiving radio messages J. L. Green's station.

Below: The switchboard controlling the apparatus in the station.

also an excellent little 10-cent galena detector is used. A pair of 1,000-ohm and a pair of 500-ohm receivers, sliding plate variable condenser, and a fixed condenser. A buzzer test is also used. The station has a small switchboard with all the instruments wired to it. For sending, a 1-inch spark coil and a spark gap are used with a transmitting key. The station is in a separate building with a 500-ampere 250-volt lightning switch for protection. I remain,

Yours truly,
ARTHUR BEOGSTROM,
Concord, N. H.

J. L. GREEN'S WIRELESS SET.

My radio station comprises the following instruments:

Sending set: $\frac{1}{2}$ kilowatt closed core transformer (under table); home-made plate glass condenser and oscillation transformer and two telegraph keys.

Receiving outfit: Home-made loose

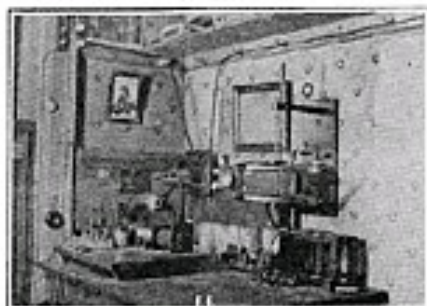

J. L. Green's station.

coupler of large dimensions, Murdock variable and Mesco fixed condensers; E. I. Co. circular potentiometer, galena and silicon detectors and a set of 3,000-ohm "Government" phones.

The "Government" phones I consider responsible for my long receiving range, viz., 2,000 miles, using a four-wire aerial 80 feet in height and 90 feet long. All instruments, both sending and receiving, are connected by high tension cable.

I find that silicon gives much better results if used in connection with a battery and potentiometer. At present all Canadian amateur stations are closed, having received orders from the Naval Department on August 15th to dismantle their sets.

I have been a subscriber to the *Electrical Experimenter* for two years, and find it practically indispensable for one who has been "bitten by the experimental bug." I remain,

Yours, etc.,
J. L. GREEN.

Rosser, Man., Can.

STATION OF HAROLD AND ETHEL HURLEY.

We are enclosing a photo of our wireless set which we would like to see appear in your monthly magazine. Taking



Radio station of Harold and Ethel Hurley: the set from left to right, will be noticed the receiving on the left and sending on the right. The receiving set consists of large loose coupler (home-made); two sets of phone of 2,000 ohms per set; two detectors, silicon and perikon; two tuning coils; one large box type variable

condenser, New York make. For buzzer tests, we use a 20-ohm relay. For sending we use a 1-inch coil and glass plate condenser which is back of coil; rotary spark gap driven at 2,000 R. P. M.; disc having 16 plugs gives us a very musical spark. Oscillation transformer being employed of Marconi type, both coils being wound with same size wire. We employ two aerials; one for receiving is 275 feet long, 40 feet high; the one for sending is 50 feet long, 40 feet high. We are able to receive 1,500 miles and send about 5 miles. We remain,

Yours very truly,
HAROLD and ETHEL HURLEY,
Lake Como, N. J.

S. W. PIERSON'S RADIO.

Herewith find flashlight photo of my wireless equipment. My instruments are of the Murdock make. The transmitting set consists of $\frac{1}{2}$ K. W. transformer



Photo of Mr. Pierson's aerial mast, and his station.

coil, interrupter, glass plate condenser, having 20 plates; large spark gap mounted on a porcelain base. Helix and key. Receiving set consists of *Electro* tuner converted into the 3-slide type, 3 detectors, Universal, peroxide of lead and a galena of my own make, an 11-plate variable condenser, etc.

With these instruments I have heard distinctly N. A. A. (Arlington), N. A. R. (Key West), W. G. O. (Chicago), S. L. U. and G.Y.C. (St. Louis), and I. W. C. O. (Springfield). The Illinois Watch Co., at Springfield, comes in very loud when sending the time. I can send about 50 miles. I have taken the *Electrical Experimenter* ever since the first issue and find it a very valuable magazine and a great help in my experiments.

STUART W. PIERSON,
Carrollton, Ill.



This department is for the sole benefit of the electrical experimenter. Questions will be answered here for the benefit of all, but only matter of sufficient interest will be published. Rules under which questions will be answered:

1. Only three questions can be submitted to be answered.
2. Only one side of sheet to be written on; matter must be typewritten or else written in ink, no pencilled matter considered.
3. Sketches, diagrams, etc., must be on separate sheets. Questions addressed to this department cannot be answered by mail.

LOADING COIL ACTION.

(239.) J. W. West, Jr., Waverly, Va., states he cannot tune in his friend's short waves sharply, using a standard loading coil, and wants to know why.

A. 1. Answering your query, would say that the reason you cannot do any tuning on short wave lengths in the manner you suggest with a loading coil is due to the fact that each step on the loading coil corresponds to about 800 meters wave length; you will therefore readily see that any tuning on short wave lengths will have to be done in the usual manner with variable condenser in series with the ground wire, if your aerial and tuner are too big.

The loading coil is only used for tuning in long wave lengths of a greater value than 1,500 to 2,000 meters. When the loading coil lever is on the first point of the dial, the inductance in same is all cut out and the coil is short circuited.

BROAD RADIO WAVES AND TUNING.

(240.) O. Adamson, Naugatuck, Conn., says his friend cannot tune out his wireless wave, and that he can be heard "all over the tuner," as they say.

A. 1. The radio troubles you speak of, as regards the tuning out of your wave, etc., by your friend, is partially due to the proximity of your friend to your station and in such a case, of course, the receiving station in question will indicate signals due to the forced oscillation impressed on it and, also, this quite possibly is due to the broad wave you are emitting.

An oscillation transformer will help you out of this trouble and a pure wave is one with a single peak, and also a wave whose logarithmic decrement is lower than 2/10, as required by the Radio Law now in effect. This matter is fully discussed in any standard wireless handbook.

EIFFEL TOWER RADIO SIGNALS.

(241.) Everett N. Davis, Antrim, N. H., wants to know where he can find data on all large radio stations.

A. 1. The operating data on wireless station at Key West, such as you desire, is given in full in the Government Radio Call Book at 15 cents, available from the Superintendent of Documents, Washington, D. C., and also the calls of all wireless stations, including a large number of amateurs which are not listed in the Government Book, are listed in Wireless Blue Book of the W. A. O. A. at 15 cents.

We are not familiar with the wave length, etc., of the Eiffel Tower station at Paris, and you will have to use some form of amplifier, undoubtedly, to receive messages across the Atlantic from them, unless you employ a very large aerial, say, 1,000 to 1,500 feet long, etc., similar to the station design followed by the Marconi company. This aerial can consist of a couple of wires spaced about 20 feet apart. You should receive the short wave stations with the apparatus you mention all right.

ROTATION OF SHUNT DYNAMOS.

(243.) Otto Larrow, Wash., wishes to know how to drive his small D. C. dynamo by a water motor running left-handed.

A. 1. Relative to the D. C. dynamo, will say that in reversing the direction of armature rotation in same, it is only necessary to simply reverse the field winding terminals on the machine where they are connected to the armature terminals or brushes.

In this way, you will see that the machine can readily be operated left handed as desired, but the machine ordinarily is supposed to rotate right handed, looking from the pulley end, when the machines are sent from the Factory.

"ANTENNIUM" PHOSPHOR BRONZE CABLE.

(244.) Norman Herbert, Pattenburg, N. J., asks several questions regarding "Antennium" phosphor bronze cable.

A. 1. Regular solid No. 14 Antennium

Want to Swap?

If you have anything to buy, sell or exchange and want to make sure of doing it quickly and at an insignificant cost advertise in the

Scientific Exchange Columns OF The Electrical Experimenter

You will find advertised in these columns:

Photographic supplies, Photographs, Wireless Apparatus, Electrical goods, Bicycles, Motorcycles, Rifles, Gasoline Engines, Microscopes, Books, Skates, Typewriters, Etc.

The owners of these things wish to "swap" them for something else, something which you may have.

The Rates

One cent per word (name and address to be counted) minimum space 3 lines. Average 7 words agree to the line. *Remittance must accompany all orders.*

The Classified Columns of the ELECTRICAL EXPERIMENTER GET RESULTS

More than 30,000 Electrical Experimenters will see your ad.

wire has about 6.19 ohms per 1,000 feet; 7-strand pure phosphor bronze "Antennium" cable has a resistance of .388 ohms per foot. While this may seem a little high, it must be remembered that the high frequency resistance of this cable is very much lower than a similar size solid conductor of bronze or copper; as with a stranded cable, the total surface

available, considering all the strands in same, is naturally much greater than for a similar diameter solid wire, as the high frequency currents only travel on the surface about 1/100th of an inch below same, not penetrating any further, especially in radio work.

WATER MOTORS AND LIGHTING PLANTS.

(245.) Clyde Hudson, Cloverdale, Oregon, inquires as to the horse-power of small and large water motors at various water pressures.

A. 1. We wish to say that undoubtedly you will gain considerable information on water turbine power plants, etc., from the May, 1914, *Electrical Experimenter* magazine. Large size water turbines are there shown and described, and also the water pressure, etc., required to operate them.

Regarding the electrical equipment for your proposition, we can suggest a 480-watt 40-volt 12-ampere D. C. generator, which is worth about \$25.00 (field regulator, \$3.00 additional), and this generator will light about ten 50-watt 90 C. P. tungsten lamps.

You may use in connection with this generator, for instance, six storage batteries of the 6-volt 60 A. H. type, connected in series; and two of these sets connected on parallel, which will give you 36-volt battery with an ampere-hour capacity of 120. This battery would light the ten 50-watt lamps for about 10 to 12 hours on one charge.

TRANSFORMER SECONDARY CHOKE COILS.

(246.) O. G. Furman, Los Angeles, Cal., wishes to know size of radio transformer secondary choke coils to use on 550 volts, 750 watts discharge energy.

A. 1. The choke coils you mention to be used in the secondary of your transformer can very well be composed of 30 to 40 turns of about No. 24 enameled magnet wire with the turns spaced a slight distance apart, same being wound on porcelain or impregnated wood cores about 2" in diameter.

These choke coils are used on most high grade radio sets installed, and also they are very efficacious in preventing the condenser surges from backing up into the transformer. They certainly should be used at both secondary terminals of the transformer, and not in one side only.

LOOSE COUPLER WON'T WORK.

(247.) R. D. H., La Crosse, Wis., has constructed a large loose-coupler as described in the *Electrical Experimenter* for March, 1914, and it refuses to work properly.

A. 1. Relative to the professional style loose coupler, of H. W. Secor's design, which you have constructed and which does not operate properly, will say that this coupler should work very finely indeed, and it will receive long wave lengths up to 3,000 meters, which, of course, covers the Arlington time signals.

It is well to carefully test out and examine your coupler switches to see that

there are no short circuits in them. The small coupler you mention will probably have a wave length capacity up to 1,500 meters. We always desire a variable condenser shunted across the secondary of a loose coupler to facilitate tuning out interference, static, and also to help tuning in different wave lengths, as the secondary circuit is tuned to the different wave lengths coming in on the aerial by means of the variable condenser and adjustable secondary winding.

PHASE CORRECTING CONDENSER.

(248.) F. Clarkdale, Ariz., writes us about an electromagnet he is using on A.C. 110 volts, and states that he thinks a proper condenser connected in parallel with it will cause the magnet coil to draw its proper current.

A. I. After due consideration of your A.C. problem, it seems to us as though it maybe that the power transformer supplying your circuit is rather too small and this would account in one way of course for the small current of one or two amperes passing through the coil, even though it had a carrying capacity of several amperes with a proportionally low resistance, etc. In other words what we mean to say is that; possibly, considering the size of transformer supplying your circuit and also the size of the wires in the circuit, that you overload the said circuit. In this case of course the action will take place you describe, i. e., the lamps would become red showing that the circuit was being "swamped for energy," so to speak. However, acting on the regular A.C. phenomena which is of course well-known, where the receiving circuit is highly inductive, we give you below formula for calculating the capacity in farads of condenser necessary to be shunted across the inductance, when it causes the current to lag behind the E.M.F. with a resultant low power factor.

L

$$\text{CAP} = \frac{1}{R^2 + (2\pi f)^2 \times L^2}$$

Where: L is inductance in henries of coil, etc.; R—Ohmic resistance of coil; $\pi=3.1416$; f—frequency in cycles.

This method of improving the power factor however is very rarely used in practice; as the condensers usually have to be very large and hence their initial cost is prohibitive. In commercial A.C. work, the usual way to improve the power factor or correct for lagging current, due to highly inductive receiving circuit, is to employ a synchronous motor on the line, such as used on motor generator sets or rotary converter sets.

A. C. TRANSFORMER FOR IGNITING GAS ENGINES.

(249.) Frank S. Anderson, Easton, Md., suggests using a small A.C. step-down transformer for igniting a wipe-spark gas engine and wants to know if it is practical?

A. I. Most probably you can very well use a small step-down transformer in the way you suggest, for igniting your gas engine. However, as your make and break contact would short circuit the transformer at every explosion, we would suggest that you utilize a regular kick or ignition coil in series with the circuit of the same type as ordinarily used with your batteries. This will tend to increase your spark at the break in the engine cylinder and also to reduce the chance of burning out the transformer winding.

IRON WIRE FOR AERIALS.

(250.) Robert Chandler, Evansville Ind., wants to know if copper-jacketed iron wire,

No. 4895

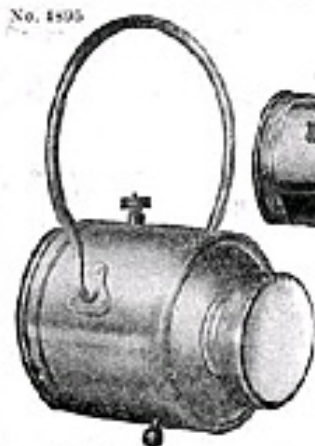

No. 4896

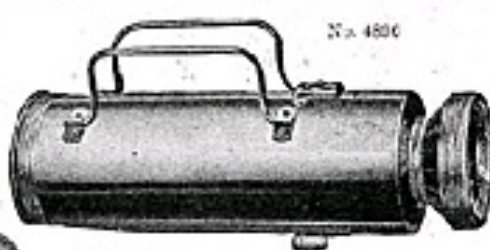

No. 5765

ONLY A FEW
ITEMS OF OUR
LARGE LINE

QUALITY  PRODUCTS

1st Class Dealers Carry Our Line

If your dealer can't supply you, write us and we will give you name of nearest dealer who can.

Interstate Electric Novelty Co.
29-31 Park Place, New York.

Chicago: San Francisco: Toronto, Can. 1
241 Wash'n Blvd. 111 New Mont'y St. 229 King St., W.



THE FAMOUS "FRANCO" PENLITE \$1.00

WIRELESS AT SPRING VALLEY,
N. Y., HIGH SCHOOL.

A wireless telegraph station has been erected in the laboratory of the Spring

Valley, N. Y., high school by Allan Sniffen, Harold Brewer and Harold Grallum. The set has given satisfaction in the tests that have been made so far.

Electric Light for Your Home

This newly invented system enables every rural home to make their own electric current; and operates from one to fifty lights and will drive small electric motor, electric fan, toaster, etc. Everything complete in one compact unit, no boiler or switchboard. Uses standard lamp and fixtures that any dealer can supply. Nothing to watch but the switch. Has stored gasoline engine, which requires no attention once a week.

The most electric lighting system for country homes. Nothing like it ever sold before. Costs less than other systems to buy and to operate. Will last for years.

Waterman Motor Company

182 E. MT. ELLIOTT AVENUE
DETROIT, MICH.

Write today for
descriptive
literature and
prices.

Uni-Lectric
GASOLINE-ELECTRIC UNIT
LIGHTING SYSTEM



FREE-SEND FOR THIS

Large Illustrated Catalogue of
**Home-Study
BOOKS**

ON
Electricity, Engineering, Carpentry,
Building, Painting, Business

Check these subjects you are interested in and mail with your name and address. We will send full particulars by return mail.

MOTION PICTURE OPERATING
..... Electrical Engineering Gas Engine Engineering
..... X-ray Light and Power Automobile Mechanician
..... Sign Bookkeeper
..... Electrical Wiring Plumber
..... Telephone Expert Mason and Bricklayer
..... Architect Carpenter
..... Building Contractor Painter, Sign and Coal
..... Architectural Draftsman Writing
..... Concrete Engineer Letter Writing
..... Mechanical Draftsman Railroad
..... Steam Engineer Mechanic
..... Stationary Engineer Tailor and Fitter
..... Telegraphy Civil Service

FREDERICK J. DRAKE & CO.
1325 E. Michigan Ave. CHICAGO, ILL.

PATENTS That Protect and PAY

Send for Free 96-page book

Advice Free. Terms Reasonable. Highest References. Best Results.

Send sketch or model for FREE examination and opinion.

Recommended Patent Lawyer in the Bankers' Register and Special list of selected lawyers.

Also in Martindale's Law Directory, Sharp and Allman's Directory of Lawyers.

The Gas-Paul Directory of Lawyers, and Kim's International Law Directory.

ALL BUSINESS GIVEN PROMPT and PROPER ATTENTION

A large list of strong recommendations furnished free.

WATSON E. COLEMAN PATENT LAWYER 622E-F ST., N., WASHINGTON, D.C.

TELEGRAPHY

The Only Trade that is not Crowded. It insures steady employment and good wages. Instruction is assured for the ambitious. We are official instructors for the Western Union Telegraph Co., and the only school instructing Western Union employees. Largest attendance of any Telegraph School; also authorized school for Illinois Central Railway Company. Accredited by State. Practical instruction; make like wire. Employment furnished to caps expenses if desired.

JONES SCHOOL OF TELEGRAPHY, Dept. E, 305 S. LaSalle St., CHICAGO, ILL.

WIRELESS COURSE

JUST ADDED. PERFECT EQUIPMENT FOR INSTRUCTION IN WIRELESS TELEGRAPHY

Write for full particulars

SMALL ENGINES

Our 1/2, 1 and 1 1/2 H. P. Gasoline Engines for Farm and Shop are the best small engines made because we specialize on them. The

"SIEVERKROPP" at \$10.00 will run a washing machine, grinder or any small machine. Buy one for your boy! Shipped on trial. Send stamp for Booklet and Special Offer

SIEVERKROPP ENGINE CO. E1224 18th St. Racine, Wis.

TELEGRAPHY TAUGHT

In the shortest possible time. The *Omnicograph* Automatic Transmitter combined with standard key and sounder. Sends you telegraph messages at any speed just as an expert operator would. Five styles, \$2 up; circular free.

OMNICROPH MFG. CO. 30 East Chestnut Street New York

A Fortune to the Inventor

who made and needs it, is the possible worth of the book we send for 6 cents postage. Write us at once. R. S. & A. B. LACEY, Dept. E, Washington, D. C.



200 Kinds Iron, Wood, Wire & Steel Puzzles
Catalog and Sample, 15c.
2 Leaders for 50c.
WESTERN PUZZLE WORKS
Dept. 33 St. Paul, Minn.



Play Billiards at Home!

Under our easy payment plan, the expense is scarcely noticeable. You will be surprised to find how easily you can own a

BURROWES

Billiard and Pool Table

No special room is needed. The Burrowes Table can be set on your dining-room or library table, or mounted on its own legs or folding stand, and quickly set aside when not in use. Burrowes tables are splendidly made and correct in every detail. The most expert shots, calling for skill of the highest order, can be executed with the utmost precision. Some of the leading professionals use Burrowes Tables for home practice. Sizes range up to 4 1/2 x 9 ft. (standard.)

THE COST IS TRIFLING

A few cents a day (far less than it costs to play in a public poolroom) will soon make you the owner of a handsome Burrowes Table. You can play on the Table while paying for it. Why not own your Table and play with family and friends in the home atmosphere instead of spending a greater amount, with nothing to show for it, for rental of a public table?

FREE TRIAL—NO RED TAPE

On receipt of first installment we will ship Table. Play on it one week. If unsatisfactory return it, and on its receipt we will refund your deposit. This insures you a free trial. Write today or mail the attached coupon.



\$100 DOWN

Terms are very easy—\$1 or more down (depending upon size and style selected), and a small amount each month. Prices from \$75 up. CASH, PAID, ETC., PLEASE.

Send for Burrowes Billiard Book: Rules and Folding Card Tables

E. T. BURROWES CO., 110 Free St., Portland, Me.

Please send catalog of Billiard Table offers.

Name _____

Address _____

or plain iron wire is all right for aerial construction.

A. I. Relative to the matter of using iron in wireless aeriads would say that in so far as the matter of copper-jacketed iron wire is concerned in aerial construction, it is stated to be all right by one of the foremost American wireless authorities, Prof. Dr. Alfred N. Goldsmith, head of the Wireless Laboratory, The College of the City of New York.

Also, we can say that quite recently Dr. J. A. Fleming, the noted English Radio authority and scientist has stated that such wire is thoroughly first class in every way for wireless aerial construction, and in fact he has said that iron wire with simply a galvanized or zinc coating is sufficient. This becomes apparent of course, from the fact that the high frequency current passing along the aerial only penetrates to a depth of about 1/100 of an inch in most cases.

LIGHTNING vs. AERIALS.

(251.) F. G. Thackberry, Tampico, Ill., wishes to know about danger from lightning when wireless aeriads are erected on roofs of houses.

A. I. In regard to the fear of lightning striking the aerial in a wireless station, will say that many people of course use aeriads every year all over this country without any trouble from this source, as long as the aerial is properly grounded in a first class manner whenever electric storms are in the vicinity.

Also, it is best to always close the ground switch from the aerial whenever the operator leaves the station or is away from same for the above reasons. Electric discharges from the atmosphere are thus conducted through the grounding switch direct to earth in a noiseless and harmless manner. A No. 4 B. & S. gauge ground wire should always be used from the lightning switch placed on the exterior of the building to the ground proper; which is preferably a water pipe or a piece of metal several feet square buried in damp earth.

RADIO QUERIES.

(252.) Albert Y—, Stamford, Conn., asks several questions on wireless matters:

A. I. Of course if you already know that you can receive the Arlington time signals by radio at your location with a low aerial as suggested; there is no need of erecting an extremely large aerial. Most probably an elevation of 40 to 50 feet above the ground with a length of 125 to 150 feet in the flat top section will serve you nicely.

You are undoubtedly mistaken in regard to the action of modern radio telegraphic receiving stations utilizing crystal detectors, etc., as these absolutely do not require a battery in most cases, especially where galena, silicon, etc., are used in the detector. These crystal rectifiers, as they are called, indicate the presence of a received radio signal by rectifying the oscillation transmitted from the radio sending station, and absolutely do not have any battery current to help them out by any relay action, etc. However, some detectors do use a battery.

CHEMICAL REACTION.

(253.) Earl S. H.—, East Allentown, Pa., inquires about a brass blacking formula.

A. I. Referring to the blacking of brass with the formula given September, 1914, *The Electrical Experimenter* will say that we have looked into this matter for you and if the copper carbonate and ammonia solution are carefully and slowly mixed, you will have no trouble from explosions; although it may effervesce somewhat at first.

AUDION AMPLIFIER TRANSFORMER.

(254.) Paul Frederick, Tiffin, Ohio, desires data on building a one to one ratio transformer for use in audion amplifier circuits.

A. I. In regard to the transformer you mention with a ratio of one to one for use with audion detectors, will say that this is made up very simply by using about

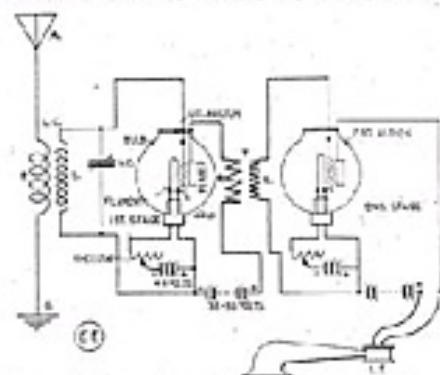

three 1/4" spark coil secondaries with an iron wire core passing through their center.

These transformers are generally arranged so that the total resistance of the coils equals 9,000 ohms. Diagram is given here for connecting same in circuit with audions; T being the transformer.

ACTION OF CONDENSERS.

(255.) John G., Tallahassee, Fla., is interested in the action and properties of condenser materials.

A. I. Your favor of recent date at hand and evidently you are laboring under a misapprehension as to the action of condensers in general. The active part of any condenser is that section of the dielectric or insulation coated on both sides by metallic leaves to charge it.

When glass plates are used in building a high voltage condenser they are invariably, nowadays, laid one on top of the other, the same as in building up a waxed paper condenser.

In regard to the number of condenser plates used in any case for a certain radio transformer, will state that this of course depends on the frequency, watts and voltage occurring at the secondary of same.

A. C. TRANSFORMERS FOR SPARK COILS.

(256.) J. W. Westcott, Springfield, O., asks several radio queries:

A. I. Batteries are usually preferred for operating spark coils, etc., but where A.C. is available, small transformers, of the step-down type, are widely employed to operate such spark coils up to 1 1/2 inch or 2 inch size.

The lead-in wire from a wireless aerial is usually composed of No. 12 or 14 bare copper wire properly insulated from the building or other structure, and it leads of course from the main aerial flat-top section down to the instruments. The standard ground wire from the instruments or lightning switch to ground connection proper is composed of No. 4-B. & S. conductor as required by the fire underwriters' rules.

(Continued from page 223.)

by the opinion of great chemists, that plants lived on carbon dioxide and gave off oxygen, thus maintaining the balance of the atmosphere. The poor plant in the glass chamber suffocates in the blanket of carbon dioxide just as a human would.

NEW ELECTRIC BREAST DRILL.

A useful and compact electric drill is shown herewith which operates on both alternating current and direct current. The spindle speed is regulated automatically by the amount of pressure the operator places back of the drill. The switch is operated by the lever outside of the switch cover and is used to start, stop and reverse the motor. The lever is spring-seated on the off or neutral position, and by throwing it to either ex-

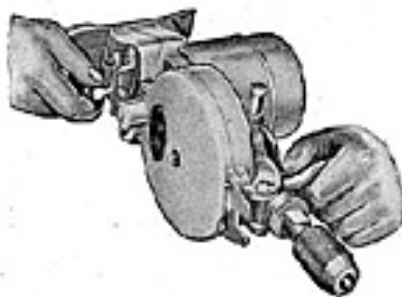

trême position the motor is run forward or in the reverse direction, according to which direction the lever is turned. The motor is quickly and easily reversed; no matter whether it is running at full speed or not. It is built by the Temco Electric Motor Co., of Leipsic, Ohio. This breast drill is unique in its compactness and practical features, all gears being well enclosed.

A NEW INSULATOR WITH NO TIE-WIRES.

A novel insulator for telegraph and telephone lines is illustrated herewith, and is so designed as to require no tie-wires. The line wire holds itself.

It is known as the Fritz Insulator, and the principal object thereof is the production of a simple and efficient means for holding the wires in their correct position without the aid of any secondary securing means.

This ingenious insulator is provided with a centrally-located slot upon the top thereof, as shown, which terminates in diverging channel portions at the end of the slot. A plurality of depending lips are formed upon each side of the insulator and constitute means for holding

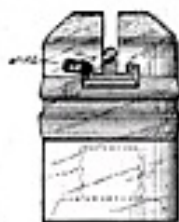

the wire in its correct position upon the insulator, thereby forming an insulator which will efficiently retain a pair of conductor wires without the aid of secondary securing means. Such a device saves a great amount of time in labor, and saves a great amount of wire ordinarily used for tying purposes. The wire is simply placed in the central slot, bent down and sideways, and then up. It is then secured against any common forces tending to dislodge it.

WIRELESS SOCIETY OF LONDON.

The presidential address of the society was delivered on Tuesday, Jan. 26, at the Institution of Electrical Engineers, Victoria Embankment, London, W.C. Mr. A. Campbell Swinton, who continues to hold the office of President for another year, chose for the subject of his address "Some Electrical Phenomena." The address was illustrated by experiments and proved very interesting.

Practical Courses of Study ELECTRICAL ENGINEERING



Chicago Institute of Technology
The Joseph G. Branch School of Engineering
CHICAGO
ESTABLISHED 1892
In Furtherance of the Education of the People
of the World

The men who get the big jobs are the men who understand the principles of electricity and their application.

Our Electrical Course teaches in plain, simple language and with easy lessons how to install and operate electrical machinery and appliances.

These lessons in Practical Electricity cover both Direct and Alternating Currents, high potential and high frequency currents, and all that is necessary to become a proficient electrical engineer.

The Course completely covers the field of practical electricity, including power-plant work, and the following subjects, viz.: Practical Electricity, Alternating Currents Simplified, The Electric Motor, Electric Wiring and Practical Mathematics.

FREE Ten text-books, handsomely bound, printed in large, clear type on fine quality of paper and profusely illustrated, are furnished free with this course.

The instruction is made so clear that any one can understand it, even though he has but a limited education.

The success of this school is due to the fact that we give the student only what he should know in order to become competent, and we do not waste his time and effort on useless matter.

THE PRICE IS LOW AND THE TERMS ARE EASY

**THE JOSEPH G. BRANCH
SCHOOL OF ENGINEERING**
608 South Dearborn Street, CHICAGO

EXPERIMENTERS

LITTLE GIANT MOTOR
Is really 2 in. high. Runs at full speed on a single cell of battery. Very powerful and may be used to run small toys, etc. Just the motor every boy has been looking for.
Sent postpaid for only 58 cents

THE SIMPLEX TELEGRAPH
An opportunity for every boy to lay in his telegraph and 50000 00's line with his share. This is a full sized telegraph set consisting of a fine key and receiver mounted on a polished base. Will work any distance. An excellent field telegraph for boys' schools.
Sent postpaid for only \$1.00.

This is the Experimenters' Reference Book

EVERY BOY NEEDS IT!
It's the latest edition of the famous AMCO Catalog, nearly 200 pages, fully illustrated. Complete description and prices of the latest Electrical and Experimental Apparatus—Storage Batteries, Motors, Transformers, Inductive Coils, Wireless Apparatus, Lenses, Flashlight, Motors, X-rays, Books, Cams, Electric Bellows, Steam Engines, Water Motors, Dynamoes, Motors, Telegraphs, Telephones, Electrical Supplies, Model Aeroplanes and parts for building your own apparatus. A treatise on Wireless Telegraphy telling how to get up an aerial, transmit messages, etc., together with a Call Sign and Wiring Diagram. FREE with every catalog. Go in stamps will bring you this wonderful book.
The best catalog of wireless apparatus, etc., published.

"The Experimenters' Supply House"
ADAMS-MORGAN CO. Dept. E., Upper
Montclair, N. J.

BOSTON WIRELESS

Boston Receiving Transformer, \$7.50
Variable Condenser, 25 Plates, \$2.75
Boston Detectors, \$1.00, \$1.75, \$1.75, \$2.75, \$4.00
Agent for Electro Importing Co. and A. W. Rowman Co., Manhattan and Adams Morgan Spark Cells, Efficiency Spark Lights and Batteries.
Catalog for stamp only.
M. MUELLER, 18 Devonshire Street, BOSTON, Mass.

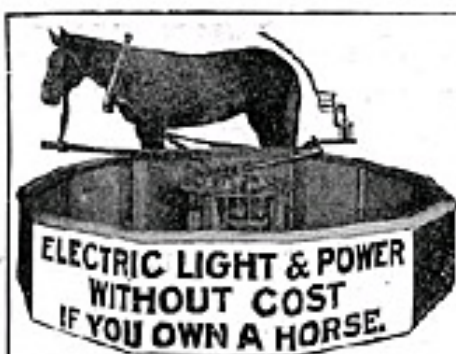

ELECTRIC POWER FOR THE FARM

No gasoline to buy; no fire risk; no expense to get out of order; always ready; two year guarantee; patented; horse power can afford it. Six hours' work of the horse makes electric light for a week or more. Write for prices and circulars. Farmer agents and dealers wanted every where.

The Electric Horsepowers Co., Mfrs.
908 Elm Street Cincinnati, Ohio

HAWKINS LIBRARY OF ELECTRICITY

In 6 Leather | Pocket Books
Price per | Volume

Here is a set of books that no man in the ELECTRICAL FIELD should do without. This is the ELECTRICAL AGG in which we live; ELECTRICITY now controls more trades, directs more men, offers more opportunities than any other power that man has yet discovered. Do you wish to know the underlying principles of MODERN ELECTRICAL PRACTICE?

If so, HAWKINS ELECTRICAL GUIDES will give you the information. In reality they are a school within themselves, containing a complete study course with QUESTIONS, ANSWERS AND ILLUSTRATIONS, written in plain everyday language so that a practical man can understand the "HOW, WHEN AND WHY" OF ELECTRICITY.



"THAT'S JUST WHAT I NEED"

They are handsomely bound in flexible black leather with gold edges and will readily go in the pocket. THEY ARE NOT ONLY THE BEST, BUT THE CHEAPEST WORKS PUBLISHED ON ELECTRICITY.

Each book is complete in itself and will be supplied \$1.00 per copy, but we believe that the complete set is the best bargain.

The books can speak for themselves and a careful examination, page by page, and illustration by illustration, will convince you of their big value.

If you will fill out the following coupon giving all the information requested, WE WILL SUBMIT THE SIX VOLUMES FOR EXAMINATION ON CONDITIONS NAMED

FREE EXAMINATION OFFER

Theo. Audel & Co., 72 5th Ave., New York

Please submit the fee examination HAWKINS ELECTRICAL GUIDES (Price \$1 each.)

Ship at once, prepaid the 6 numbers; if satisfactory I agree to send you \$1 within seven days and to further mail you \$1 each month until paid.

Signature

Occupation

Business Address

Residence

Reference

WARSHIP A MAGNET FOR WIRELESS TORPEDO.

John Hays Hammond, Jr., has taken out over one hundred patents on his wireless torpedo which is pronounced by military men to be a radical development in military engines.

The wireless torpedo travels at a 23-knot speed, carries 4000 pounds of explosives, against the 300-pound capacity of the present torpedo, and responds automatically to radio or searchlight waves, which may be directed against it by an enemy.

Instead of being protected by its lights and wireless, a hostile dreadnought literally becomes a magnet for the torpedo.

SUNBURY, PA., AMATEUR ON THE JOB.

Charles E. Newberry, of Fourth street, has purchased a fine wireless receiving outfit. The apparatus is very sensitive and will receive messages from all parts of the United States and even the border towns of Mexico and Canada.

UNDER-WATER TELEPHONES.

A telephone recently perfected by Prof. R. A. Fessenden, that weighs eight hundred pounds, about the size of a large packing case, which needs strong currents of electricity for its operation, has been constructed for telephoning short distances through water, or for telegraphing distances of from thirty to forty miles under water.

The diaphragm of the telephone, corresponding to the thin piece of japanned sheet metal that is generally to be observed in the transmitter and the receiver of ordinary telephones, is a great disk of steel, nearly two feet across and almost an inch in thickness.

By means of this telephone it is possible not only to telephone short distances and telegraph long distances under water, but to detect icebergs in the neighborhood of a vessel.

Vibrations sent out from the telephone will return as echoes from the sea bottom or from an iceberg; and by measuring the time taken for the return of the echoes, it is possible to estimate very closely the distance of an iceberg or of the bottom.

The instrument is suspended in the water by a derrick on the ship, and wires lead a strong current of electricity to it. This power causes the heavy diaphragm to vibrate at the rate of about five hundred vibrations a second, and the water carries these vibrations just as air carries sound waves. At the other end of the wires a delicate telephone receiver catches the vibrations—the better results for long distances are obtained by catching the vibrations in another big receiving apparatus devised for that purpose.

Induction Balance Locates Bullets.

(Continued from page 231.)

was accurately determined. The general features of the Hughes induction balance are represented in Fig. 1, in which A and B denote two parallel equal coils of wire similarly wound and so arranged that the distance between them is adjusted at will. These coils are connected by flexible leads, as shown, with another pair of equal coils C and D; oppositely wound, mounted parallel to each other at a fixed distance. Into the circuit of A and C is interpolated a battery and a microphone F, while a telephone G

The 1915 Electric Light



New Motorcycle Type

Write for New Catalog.

The biggest bicycle value ever built. Read the wonderful new 1915 improvements. Nothing like this ever offered before.

The New 1915 Arrow—a positive wonder for beauty, speed, easy riding and comfort. A perfect motorcycle type. All new for men, boys, women. Write today for new catalog.

Special Pay As You Ride

Write today for our special, rock-bottom direct offer. Just a very small amo and down and we will ship you this sensational 1915 Arrow. Start riding and enjoying this bicycle wonder right away—and pay for it while you ride. Write for full details.

Write Today Send for free catalog of this wonderful motorcycle type, 1915 Arrow. Also particulars of our special, rock-bottom direct offer. No obligations. Just send a postal today.

Arrow Cycle Co., 12th Street and California Avenue Chicago, Ill.



Never be without one. It must be carried in pocket or bag.

This Pocket Stove—only 50c

Burns Lava Fuel—Alcohol Saturated

No fuel to fill or replace. No oily fumes, no soot, no smoke, no odor. Burns trouble and time many times a day. Has no equal for cooking a heavy meal, heating a chafin dish, boiling water, warming baby's milk, heating coffee; ideal for campers and travelers.

ORDER ONE NOW—Send 50c and we will mail the Lava Heater, prepaid, with fuel made for instant use. An excellent gift. Guaranteed satisfactory or money refunded. Keep extra supply of Lava Fuel on hand; large can, 50c. Descriptive literature and name of dealer on request. Write today.

THE HILANEM CO., Inc.
712 East 12th Street
New York City

LAVA HEATER

Patented, Trade Mark Pro.



A useful gift. A necessity for dining room, bedrooms, bathroom, etc.

SOME CAR! BOYS! Send for Booklet Today



The Lad's Car

Send for today for Booklet, telling how to build this automobile. Complete instructions and descriptions of parts and also illustrated with diagrams, blue print, etc. made from photographs, and list of parts.

Special inducement to first boy in your town
NIAGARA MOTOR CAR CORP
Dept. EE, Niagara Falls, N. Y.

Carleton Lighting Generators

Direct Current—5 Volts—8 Amperes (48 C.P.)

With single, adjustable, portable and cut-out if desired.

A perfect lighting unit at a price lower than ever before published. Can be attached to any automobile or motor boat, or used for charging storage batteries, etc.

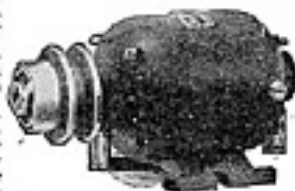

Special Ford brackets allow attachment to Ford cars by using wrench and screwdriver only.

THE CARLETON COMPANY

Fast, Top Quality—Generators—Storage Batteries
1787 Sumner Street, Boston, Mass.

Sunshine Lamp 300 Candle Power FREE

To Try In Your Own Home

Turns night into day. Gives better light than gas, electricity or ordinary lamps at one-tenth the cost. For houses, stores, hotels, churches, etc. It costs you nothing. It works as long as you have gas. No wick, no chimney, absolutely safe.

COSTS 1 CENT A NIGHT

We want one person in each locality to whom we can refer new customers. Your advice is appreciated. See R. M. KING, 240 W. 4th St., New York City. Write today. Act Now. Write to:
SUNSHINE SAFETY LAMP CO.
282 Factory Bldg., Kansas City, Mo.



Copy This Sketch

and at \$100.00 what you can do with it. You can earn \$200.00 to \$1000.00 or more per week. My practical system of personal individual lessons by mail will develop your talent. Fifteen years successful work for newspapers and magazines qualifies me to teach you every tip. Write me your sketch of yourself. Within 48 hours I will send you a 500 word sketch. Also collection of drawings showing possibilities for 1915.



THE LONDON SCHOOL of Illustrating and Cartooning
143 E. 57th Street, New York, N.Y.

AGENTS \$24 A WEEK

R. M. King Made \$45 in 6 Days



15 IN ONE

Forced steel. Patent. Low priced. Sets to turn over, reverse, machine in the shop and the house. No oil in store. No competition. Sales easy. Big profits. Ten-inch sample to workers. Write at once.
THOMAS TOOL CO., 2409 W. 2d St., Detroit, Mich.

5 H.P. 1915 Peerless Motorcycle



with Five Engine, both Magneto, Ignition, etc. It is the best there is in the motorcycle business. Speed, Silence, Endurance, and it is a working machine.

QUALIFIER essential for low cost of maintenance. 5 Miles for One Cent. Agents Wanted—Liberal Discount.
PEERLESS MOTORCYCLE CO., 175 E. 57th Ave., East, Mass.

EARN TELEGRAPH

Home and Wireless—E. E. Armstrong. Only on Agency! Secret. Specialized on profitable. Post-office secured. Manual No. 1. Take out a business proposition. No own and exclusive agency. Two large modern buildings equipped with R. E. and Western Union Wires and complete Morse and Automatic Station. Largest School—established 1878. 1000 students. 1000 teachers. By William Armstrong and Western Union Co. Official. Expert practical teachers. Low living expenses. Daily earned \$100.00. Call now. Easy payments. Correspondence courses also. Call now.
Peer's Telegraph R. & Wireless Institute
2115 Street Valparaiso, Ind.

WIRELESS MINERALS

Send 50c. in stamps or cash for 5 Bottles of Minerals, assorted in a neat carton—Galena, Silica, Carbonates, Fluorite & Borealis. The direct detector mineral outfit ever offered. Complete, 5 bottles and box **50c.**
THE ELECTRO-GET CO.,
1993 E. 8th St., Cleveland, O.

forms part of the circuit which includes B and D. A clock H mounted on the frame of the microphone gives rise by its ticking to a succession of variations in the microphone current, and by induction a current corresponding to each tick of the clock is generated in the

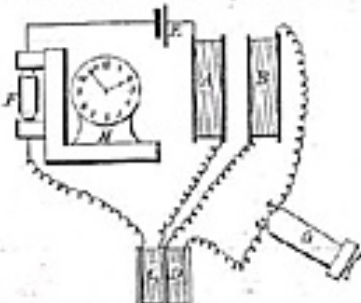

telephone circuit. Since, however, the coils D and C are oppositely wound, while A and B are similarly wound, the current induced in D tends to oppose that induced at B, and by adjusting the distance between A and B, the one can be caused absolutely to neutralize the other, in which case the ticking of the clock is inaudible in the telephone. If, however, after this balance is secured, the pair of coils CD are brought near a piece of metal, such as a bullet, currents are also induced in this metal, and some of the energy which would otherwise produce current in D is dissipated in the bullet. The consequence is that the balance is upset and a new adjustment of the distance between A and B must be made in order that the telephone may remain silent. The nearer the coils are brought to the bullet, the more exactly their center line intersects the bullet, the louder is the sound in the telephone. Hence, by bringing the coil over the body of a wounded man the direction in which the bullet lies can be ascertained, while by noting what adjustment of A and B is necessary to reduce the telephone to silence, the depth below the surface can be found, since it is only necessary to find the distance from CD to which a similar bullet must be brought in order that the telephone shall be again reduced to silence, after the coils CD have been removed from the neighborhood of the patient. Many other uses can be made of the Hughes balance, such as detecting counterfeit money, locating hidden or natural metallic deposits in the earth, et cetera.

A THERMOCOUPLE ELECTRIC GENERATOR.

(Continued from page 231.)

In the apparatus developed by Mr. Marshall 16 rings were employed, making a total of 800 couples. The rings may be connected in parallel, series or parallel-series to obtain the desired voltage. A sheet of insulation is interposed between the heating tube and the hot contacts of the couples to prevent the elements being short-circuited. The air emerging from the cooling case may be utilized for heating the building in which the apparatus is installed. According to experiments which have been conducted with this apparatus, about 5.5 lb. of lignite must be consumed per kilowatt-hour of energy produced. The cost of installing a thermo-electric generating equipment as compared with steam, gas and petroleum-engine-driven plants of the same rating is declared to be in the ratio 13 : 26 : 30 : 38 respectively. The cost of producing energy in the new plants is stated to be within reason.

INVENTORS Our Brain Belongs to You. Our Ideas Are Free of Charge.

It's the best in the world. It is built for you. It's your mind, your machinery, your tools, and lips to make them speak. We are experts in building over thirty years' experience and have a lot of best opportunities in the country. See our circular No. 12, containing free experimental work strictly confidential.

A. NACK & SON
2. Sherman St., Philadelphia, Pa.
236 E. 9th St., Philadelphia, Pa.

FLY BUILD

We have accurate scale drawings and knock-down parts of a 11' man-carrying airplane for classification, exhibition purposes, models of aeroplanes, etc.

371 CURTIS FLYING BOAT

Complete Set of Six \$1.25 Postpaid.
20 pp. "Ideal" Model Airplane Supply Catalog No. IDEAL AEROPLANE & SUPPLY CO.
74-82 West Broadway, New York

WONDERFUL New Camera

The newest invention in cameras. Scientifically advanced and easy to operate. It is a perfect camera. It is a camera with a special lens. It is a camera with a special lens. It is a camera with a special lens.

Ingenio Cameras

Write for The Camera Book. 250-358 E. Ontario St., Dept. 1101, Chicago, Ill.

Wide Awake Agents! MAKE BIG MONEY BE YOUR OWN BOSS

C. C. Coy.

You need no experience. Our line sells itself. We have the most complete, fully guaranteed line of knives, razors, cut-throats and other specialties. Our Knives and Razors are hand forged, made of genuine Edge Hill razor steel. We will put any photo or litho picture on one side of the transparent handle and name and address on the other.

Write for catalog and terms—exclusive territory.
GREEN RIVER CUTLERY CO., 552 W. Lake St., Dept. E, 129, Chicago

ELECTRIC LIGHT OUTFIT 50¢

12 Volt Tungsten Lamp, 100-watt, 10-foot of Wire and Battery all complete for 50c, and 10c extra for parcel-post to any part of the world.

W. A. Danner Co.,
Freeholder, N. J.
E. S. A.
Send for Catalogue

FREE GLIDER

Why waste money on inferior models designed by laymen? Get your supply. Free expert and complete instructions for building a 10-foot glider. No need for engine, propeller and motor. With FREE Glider. 10 cts. plus the postage.

WALTER H. PHIPPS, Dept. E, 103 5th Ave., N. Y. C.



Startling New Ideas in Watches

Tell Time At Night!

Send for watch catalog describing, among others, the new radium dials that shine at night—the remarkable discovery that enables you to read time plainly in pitch darkness!—Also other new ideas.

Ribbon designs
Enamel decorations
Rich gold and color effects—

your initials in colors on a rich gold background. The new catalog shows many other novel ideas in Burlington Watches.

On Approval: The New radium dial Burlington or any other Burlington, with your own movement mounted on the radium gold strike case, will be sent to you on approval, prepaid, without a cent in advance. You make a satisfactory return by paying nothing—just one cent, unless you want the new design after seeing and approving by inspecting the watch.

If, after examination you decide to keep it, pay only the **great** post-button price—the price that even the wholesale jeweler must pay. A.C. in order to encourage everybody to secure this watch at one low price—factory price, either for cash or \$2.50 a month. Remember—we send this watch on approval.

Send the Coupon for New Watch Book

Learn the inside facts about watch prices and the many surprising points of the Burlington watch products. Just send the coupon or letter or postcard—no delay—write today—let us send you the watch if you like.

Burlington Watch Co.
190 West 1st St.
Chicago, Ill.

Burlington Watch Co.
190 West 1st St.
Chicago, Ill.

Please send me (with best obligation and prepaid) your free book on watches, with full explanation of your coupon. I'll hold a month offer on the Burlington Watches.

Name _____

Address _____

FREE—Increase Your Income
IN AN UNDEVELOPED, PROFITABLE FIELD
Learn Show Card-Writing and Lettering. We furnish a reliable and thorough course, absolutely free, to introduce ALPHA colors. If you purchase an assortment to use while practicing. Particulars for stamp.

ALPHA COLOR COMPANY, Inc.
Dept. T, 1320 Broadway, N. Y. C.

PATENTS

Formerly Member Examining Corps U.S. Pat. Office
Patent Lawyer
Patents, Trade Marks, Copyrights, Patent Litigation
Handbook for Inventors, "Protecting, Exploiting and Selling Inventions" sent free upon request.
210 McHILL BLDG. • WASHINGTON, D. C.



MORE MONEY FOR YOU
Increase your income writing show cards. Our course is for ambitious men and women. Complete course necessary. Our practical course teaches you clearly and explains the remarkable results obtained with **Lithotype** writing. **Write us your name** now. Don't lose about the money. If you are ambitious and want to receive an expert show card course. Write now at once. **LITHO TYPE COLOR CO., 1325 Flatiron Bldg., New York.**

STAMPINGS

Metal Spindles and Stampings a specialty. All sets of die work and metal patterns. Manufacturers of patent specialties and novelties. Can get out samples of moderate cost. Experts in black enameling. Prices reasonable. Prompt delivery.
The Standard Spinning and Stamping Co.
E STREET TOLEDO, O.

PATENTS THAT PAY

OUR TRADE-MARK
OVER \$600,000.00 MADE BY CLIENTS

PATENTABILITY REPORT

Good sketch as needed for your invention for free search of the Patent Office Records and report as to patentability.

TWO WONDERFUL BOOKS FREE:

Entitled "Inventors Guide" and "What and How to Invent—Proof of Patents in Patents."

Highest References, including 100 manufacturers to arrive.

PROFITNESS ASSURED
Across the Street from the U. S. Patent Office

E. E. VROOMAN & CO., 879 F Street, N.W., Washington, D. C.

* KNAPP * KNAPP *

BOY ELECTRICS
THE KNAPP LEADER
—THE BEST PRICE \$2.50

Guaranteed as
Expressed



Many other models at all prices. Live orders only. Order direct or ask your dealer to show you the Knapp line and limit on other Knapp goods. Don't get already handled Knapp line elsewhere for price. Catalog illustrating in line of dynamo, motor and electrical specialties on request.

Knapp Electric & Novelty Co.
523 West 51st St. New York

* KNAPP * KNAPP *

BOOK REVIEW.

"Essentials of Physics," by Daniel W. Hering, C. E., Ph. D., L. I. D. The D. Van Nostrand Co., New York. \$1.75 net. 354 Pages. 166 illustrations. Size 6x9 inches. Cloth.

THIS book is an excellent rearrangement of the prime essentials of experimental physics, and Dr. Hering certainly is to be complimented on producing such a clear treatise. It starts the student with a clear explanation of the make-up of matter, as we understand it to-day, gradually leading up to the laws of gravitation, heat, liquids, electrical units and action of apparatus, the refraction, interference, etc., of light rays, and measurement of its wave length, lenses and their functions, the Electron theory and its meaning, the vibration of bodies such as rods, wires, etc.

The section on Potential, Magnetism and Electricity will be found of great interest to our readers, as a number of good experiments with clear illustrations are shown. X-Rays are covered at length in an up-to-date manner, also radio-activity, and the discharge of electricity thru gases. Wherever necessary, the mathematics of each law or problem are given but these are for the most part very simple. In the whole volume there are 100 easily conducted experiments for the student of physics. The book is well adapted to the lay reader, the high school boy and the college student. Dr. Hering's work can be obtained at \$2.00 from publishers of this journal.

"Text Book On Wireless Telegraphy," By Prof. Rupert Stanley, B. A., M. I., E. E. Longmans, Green & Co., London and New York. \$2.25 net. 344 pages. 201 illustrations. Size 6x9 inches. Cloth.

A volume which reminds one of Dr. Fleming's large reference book and classic, but which is, if anything, written on a much clearer plane for the average radio man, including operators and engineers. The Marconi apparatus is featured throughout the work, because it is the most widely used all over the world for both large and small radio stations. Prof. Stanley has given us a very useful book indeed, it seems, in this well illustrated and complete work. The formulas necessary are cited and explained in a clear and up-to-date manner. The style of the book is such that the beginner in the art can learn from it as well as the expert. Many new subjects are covered in the various chapters, and it will pay everyone interested to read it thru.

Among the interesting subjects embraced are: How ether waves are propagated; historical development of radio-telegraphy; oscillatory discharges; induction coils; transformers and alternators; electrical measurements and calculations; measurements in radio-telegraphy; undamped wave systems (all types); detectors, including Fleming and De Forest gas valves; receiver circuits, etc., et cetera. The chapter on aerials, insulators and earth connections is very well written, and it covers the ohmic and radiation resistance of aerials, et cetera, in a lucid manner easily understood by anyone. The formula of Rudenberg for calculating the equivalent radiation resistance of "L," "T" and umbrella aerials, is given; also the formula, and laws for computing the radiated energy from such antennae.

Quenched and rotary spark gaps are well covered with the design features controlling them, and also the efficacy of such oscillation generators, and the best kind of transformer to use.

Opportunity Exchange

YOU will probably find more opportunities and real bargains in these columns than anywhere else in the country. Most good things in life are hard to find and worth going after—these little ads illustrate that point; you alone will be the real loser if you don't take the time to scan through these columns.

Advertisements in this section to a word for each insertion. Count 7 words per line. Name and address must be included at the above rate. Cash should accompany all classified advertisements unless placed by an accredited advertising agency.

Ten per cent discount for 4 issues, 20 per cent discount for 12 issues from above rate. Objectionable or misleading advertisements not accepted.

Advertisement for the May issue should reach us not later than April 15th.

THE ELECTRICAL EXPERIMENTER, 133 Fulton Street, New York, N. Y.

BOOKS

'TRAFFIC in Souls.' This book is based upon the most widely discussed motion picture production. It is a powerful study of vice conditions in New York, and the facts upon which it is based were compiled from the Rockefeller White Slave Report. Illustrated with striking photographs. 200 pages. Send request for 50c. Thomas Mercantile Co., 17 East 22d St., New York.

HANDSOME presents to new subscribers' list: catalogue of 3,000 publications, 4c. Edwards Magazine Agency, Atlantic City, N. J.

'HUNDRED Ways to Kiss a Girl' and other things. Something real good. Price 25c. Bronx Girls Club, 417 E. 124th St., New York.

PIGEONS—The Great Pigeon Magazine, \$1.00 a year, or send 25c. for four months' trial. Pigeon Magazine, 943 Advertising Bldg., Chicago.

MODERN Dances—Best instruction book for beginners. 11 dances fully illustrated. 25c. Franklin Deane Publishing Co., 509 Fifth Ave., New York.

ENGINEERS' questions and answers for 1-year, by Nelson for 25c., postpaid. Send stamps. Kelly's Book Store, Philadelphia, Pa.

BICYCLES AND MOTORCYCLES

CLOSING Out Sale high-grade slightly used motorcycles. We have about 50 left to sell, in standard makes which we are offering at big bargains, such as twin and single-cylinder Indian, Harley-Davidson, Merikola, Tocco, Excelsior, Pope, 4-cylinder Henderson and Pierce. These motorcycles we want to close out this year. No reasonable offer will be refused. Write to-day for our list giving description and prices. Ogden Sporting Goods Co., 27 Warren St., New York City.

FOR Sale cheap. 1914 Harley-Davidson twin. Write for particulars. Walter Goetz, 221 Washington St., Newark, N. J.

1908 H. D. SINGLE with clutch and magnets, \$20. **1910 H. D. battery model.** A-1 condition, \$25. **1911 H. D. single** magnets model and clutch, \$40. **1910 H. D. clutch and magnets, \$45.** 1 Indian motorcycle motor with magnets and Schlicher carburetor, \$25. 1 Excelsior motorcycle motor, \$25. C. H. Long, 1704 Michigan Ave., Chicago, Ill.

\$50 TO \$150 buys the best motorcycles, every make and model in our large stock—must be cleared. Half price. Send for list to-day. Talk to Michigan, \$2 and up. Brown Music Co., 9120 Commercial Ave., Chicago, Ill.

SEND for latest Bulletin of real Motorcycle Bargains, used and slightly used, all makes, models and prices; if you save \$20 and really want a powerful motorcycle, send for this Bulletin! Hundreds of machines at all prices, new ones 90 cent payment tell us what you want and how much you can pay! We can fit you up. Peerless Motorcycles Co., Danvers, Mass.

USED Motorcycles, all makes, bargains. Send for list. Wood Bros., 213 Broadway, Camden, N. J.

OUR folder showing the new '15 Eagle 2-speed model is ready for mailing. Write for this and for the agency to-day. Sterling Motor Co., Brockton, Mass.

HIDERS! Write for our catalogue of motorcycle accessories and supplies. Andrews Specialty Co., 55 Warner St., Rochester, N. Y.

4-BORNE Pierce, single cylinder, magnets, solvent carburetor, new tires, perfect running order. \$125.00. Free Gilt, 20 Forest Ave., Fairbank, Alaska.

GET copy of "Motor Cycle" published in England. Special War Issues received here weekly. Price 15c. Two for 25c. Distributors, 143 So. Wabasha, St. Paul, Minn.

WE have 22 used motorcycles from \$50 up. Ask for list. Will save you money. Answer quick. Sterling Motor Co., Brockton, Mass.

1914 MODEL B Pope Two-Speed Motorcycle—Will exchange for 15-inch swing Engine Lathe. E. H. E. Thibault, Sherwood, Ohio.

Big bargains in good motorcycles we have taken in exchange on new ones. Send for special bargain list. Shaw Mfg. Co., Olathe, Kan.

MOTORCYCLES—Everybody rides them. You've used. New and rebuilt motorcycles; every motorcycle fully guaranteed. Magnis and Union, \$25 to \$100. Tire casings, \$5; belts, \$4; carburetors, \$6; automobile tires, \$1. Send for catalogue. Designer, the price cutter, Rochester, N. Y.

MOTORCYCLES cheap now. Write me what you want and price. Chas. Walsh, 878 St. Paul, Detroit, Mich.

MOTORCYCLES, all makes, rebuilt, guaranteed good as new. Indian, Harley, Excelsior, Henderson, Kallister, Merikola, single and twin, \$25 to \$100. Day direct, save dealer's profit. Designer Cycle Co., Rochester, N. Y.

DON'T buy a Bicycle Motor Attachment until you get our catalogue and prices. Shaw Mfg. Co., Dept. 22, Olathe, Kan.

YALE, Pope, Thor, bargains. Late models. Walter Manger, Knoxville, Tenn.

FORMULAS

LATEST FAD. The celebrated everlasting fragment rose buds can be easily made and sold with big profit. Stings sell as high as \$5.50 to \$6.00. Formula with full instructions for making same, 25 cents each. J. C. Kegan, 1162 Broadway, New York.

Is the formula you want worth a quarter? Right exact requirements. Raymond, Rochester, N. Y.

1,000 TRADE secrets and formulas, 25c. 500 selected formulas, 20c. Resistor mixtures, guaranteed process, 20c. Make Saveling Powder and Rich Powder, 10c, each. Entire lot, 50c. Service Bureau, 3111-V, Belleplaine Ave., Chicago.

MAKE Candy everlasts, bars, receipts, 10c. Elmer Zimmerman, 1435 Walnut, Hainsburg, Pa.

START factory making candy, gum, cracker, jerk, orange, cider, etc. Kells fast. Nearly 40 profit. \$10 course \$1.00. Catalog, 20. Robert Hamilton, Kansas City, Mo.

SIX valuable formulas for sympathetic ink, 50c. Wayne Thomas, Ithaca, N. Y.

FORMULAS for ink, black, blue, red, gold, green, silver, indelible, 10c each. 7 for \$1.00. Stephen Roberts, 2122 Arch St., Philadelphia, Pa.

PHOTOGRAPHIC

WE buy, sell and exchange. Bargains in microscopes, telescopes, binoculars, cameras, etc. Bargain list sent. Talk to Sam Optician, No. 54 John St., New York. Established 62 years.

SEND Cash paid for high-grade Kodaks, Lenses and Cameras. Send full description, stating lowest price. Cameras exchanged. In business since 1885. David Stern Co., Dept. M, 1017 W. Madison St., Chicago.

FILMS developed, 10c. all sizes. Prints 2x12 $\frac{1}{2}$, 3x: 2x4 $\frac{1}{2}$, 3x4 $\frac{1}{2}$, 3x4 $\frac{3}{4}$, 4c.; Post Cards, 50c doz. Work guaranteed and returned 24 hours after receiving. Postpaid. Send negatives for samples. Girard's Commercial Photo Shop, Holyoke, Mass.

SOLE Films developed 10c. per roll. Printing Post Cards, 5c. each. 15 years' experience. Give me a trial. You will be pleased. F. C. Hoyt, 240 City, Ill.

EXPERT Kodak Finishing Send for price list. Electric Studio, 102 Stephenson St., Peopler, Ill.

KODAK films developed, 5c. all sizes. Prints, 5c. each, any size. F. Johnson, 109 W. Bridge St., Oswego, N. Y.

TRANSFERS pictures to china, etc.; no formulas; pastels, etc. Price, 285 West 142nd St., New York City.

THINK OF IT! Only \$20 for finest German Double Anamorph in lens shutter, for 3A Kodaks and postal card camera. Send for matter concerning best terms on earth at very low prices. Halbury Co., 305 North Fifth Ave., Chicago.

FILMS developed, 10c. all sizes, prints 2x12 $\frac{1}{2}$, 3x: 2x4 $\frac{1}{2}$, 3x4 $\frac{1}{2}$, 3x4 $\frac{3}{4}$, 4c.; Post Cards, 50c. dozen. Work guaranteed and returned 24 hours after receiving. Postpaid. Send negatives for samples. Girard's Commercial Photo Shop, Holyoke, Mass.

354 CENTURY Grand, bargain, \$20. Magnificent Kanga Reflex, Zeiss Triolar Anamorph, complete. \$20. \$22.50 Autographic Kodak, \$19.75. Elips Calendar Mount, assortment, \$1. Catalogue mailed. Newark Photo Supply Co., Newark, New Jersey.

HEADQUARTERS for selling or exchanging Cameras of all kinds. Carry a full line latest Kodaks, Graflex, Ikonos, foreign Cameras. Write for big bargain list. Gluckman & Newby Co., 171 Broadway, New York.

KODAK Films Developed, 10c. per roll, any size. Prompt attention given mail orders. Prints, 2x12 $\frac{1}{2}$ to 3x4 $\frac{3}{4}$, 5c.; 4x6 to 3x4 $\frac{3}{4}$, 4c. J. M. Marling, Box E, 1062 Third Ave., New York City.

PRINTING

OUR splendid plan of Publishing a Magazine of your own, will increase your business. Let us send you free particulars. Co-operative Magazine Co., 2520 N. Clark St., Chicago, Ill.

PREPAID Printing (300 miles) 1,000 best letter heads, \$1.25 envelopes, \$1.15; return envelopes, \$1.25; 100 station typewritten letters, 10c words, \$1.75; 100 words, \$2.00; (25 circulars, \$1.75; all ad slips, \$1.00. Ask for prepaid prices on any printing. Good's Quick Print, Harrisonburg, Va.

MAGIC AND TRICKS

MAGIC pocket trick free. Worth 25c. With illustrated catalog of 250 tricks, puzzles, illusions, for 5c. Stanley Magic Co., Box 18, 242 West 25th St., New York.

POST Cards, Tricks and Jokes, Colored Notes, Stamps and curious things. Catalog for stamp. Cox Exchange, New Rochelle, N. Y.

BIG Catalogue. Magic, Entertainment goods free. Bates Co., Melrose, Mass.

MAGIC Tricks John and Pandion. Trick with my catalogue, 10c. each. H. V. Ellis, Huntington, W. Va.

GREAT book wonders, secrets and mysteries and novelty catalogues, 10c. Wright Spec. Co. (D), Brewster, N. Y.

MAGIC tricks for the profession. 10c catalogue and pocket trick free. Vestibular Science, \$6.00 up. Magic Factors, 132 Clifford, Providence, R. I.

NOVELTIES, Books, Tricks, Games, etc. Illustrated catalogue free. Sample 25c. cash trick, 10c. Arthur Roberts Co., Specialty Dept., 7745 Pecos St., Chicago.

SECRET-WRITE! New System of secret writing. Keeps your correspondence safe and private. Strangers cannot read your cards and letters. Great fun for everybody. Samples and instructions, 10c. H. J. Temple, Decatur, Indiana.

GREENBACKS—Yellowbacks, Stage money. New kind, 10c. worth; 4-25c. Eastern Supply, 122 East N. Kenesh, Chicago.

200 MAGIC Tricks with cards, coins, etc., 10c. Greenbacks, big wild, 10c. Novelty Shop, 3311-V, Belleplaine Ave., Chicago.

You benefit by mentioning "The Electrical Experimenter" when writing to advertisers.

GREENBACKS Big, med, 10c, 4-50c. Enter-price Co., 1092-12th, Norton Bldg., Chicago.

SAVING Bargain Sheet and Catalog 25. Gilman, Morgan Park, Ill.

GIVE us the "creeps" with the Mysterious Skull. Shines, without any light, in the dark. Really wonderful. 10c. Bartlett, Box 100, Mt. Vernon, Mo.

FAKE Money—Big, med, 10c. Gilman, Morgan Park, Ill.

MAGIC disappearing coin and ring trick, 194-tines, various. Send 10c. in coin. Calfax, Powell Sales Co., Dept. E., Oshkosh, N. Y.

BE a Magician. Travel give shows; odd money, 1 toll box. Send stamps. Prof. Rapp, Box 1111, Madison, Wis.

BE a business king. We teach you. Escape from handcuffs, boxes, ropes, etc. Receipts of 20 successful escapes, \$1. Particulars free. The Magician Co., Dept. A, Box 251, Detroit, Mich.

TRICKS, punting, jokes, cards, etc., ventriloquist figures, magic goods, seasonal escapes and illusions. Big catalogue free. Oshkosh Magic Co., Dept. 150, Oshkosh, Wis.

MODELS

MODELS made for inventors; general machine work; designing and perfecting; developing automatic devices and machinery; in a position to do all kinds of light tool and machine work. Prices reasonable; estimates cheerfully given. Ideal Machine Works, 62 Ann Street, New York City.

INVENTORS: We manufacture metal articles of all kinds in order. Also special machinery, tools and dies, punchings, lathes and screw machine work, metal patterns, castings, plating, wood and metal patterns, etc. Send us your estimate and expert advice. Free. The Eagle Mfg. Co., Dept. B, Cincinnati, Ohio.

I MAKE models for inventors and guarantee first-class workmanship; also do repair work and light manufacturing. George Wood, 223 Postal Telegraph Bldg., Kansas City, Mo.

PRODUCERS of Results; inventions developed, Light Mfg. Models, Experimental Work, Tools, Dies and Stampings, Jakes Machine & Stamping Works, Middle Bldg., Dept. C, Cleveland, Ohio.

FREE catalogue of tool supplies. Catalogs, metal specialties on contract. North Chicago Tool Works, 15 Grove Ave., North Chicago, Ill.

WE make working models for inventors; also dies and stamping of specialties, and carry a complete stock of tool gears and model supplies. Send for catalogue. The Placer Model Works, 1405 Pierce Ave., Chicago, Ill.

ELECTRICAL and mechanical inventions developed, drawings, models, machinery, tools, etc., designed and made. Plans work manufactured. Commercial Engineering Co., 142 Market St., Newark, N. J.

STAMPS AND COINS

STAMP Album, with 100 Genuine Stamps, Incl. Rhinoceros, Congo tiger, China (dragons), Tobacco (stick), Jamaica (waterfalls), etc. 10c. 100 diff. Jap., N. Zid, etc. Sr. Big list, coupons, etc. Free. We buy stamps, Hussain Stamp Co., St. Louis, Mo.

100 FOSTER Stamps Free. Send your name and address on postcard to A. S. Hinds, 182 West St., Portland, Maine.

FREE War Ticket to approval applicants. Reference: Litter, Rock Island, Ill.

FOREIGN Stamps Free, 52 different foreign, including China and Yonozaki, to all who apply for our high grade approval selections. Send two cent stamp for return postage. Edgewood Stamp Co., Dept. H, Milford, Conn.

\$125 EACH paid for U. S. Flying Eagle Cents dated 1853. Hundreds of other U. S. and Foreign Coins wanted. Send Ten cents at once for New Illustrated Coin Value Book, 47c. It may mean your good fortune. Clarke Coin Co., Box 94, Le Roy, N. Y.

MISCELLANEOUS

KEYLESS DOOR LOCKS placed on any case without tools. Pocket size, 20c; postpaid. Order sample, get to work. Postals not answered. Hooter Novelty Company, Indianapolis, Ind.

AGENTS—Big money in perfumes, toilet articles, etc., make them yourself—we show you how. Mixon Supply Company, Longbeeps, N. Y.

GASOLINE Engine Castings, with drawings, cheap. Catalog for stamp. Novelty Manufacturing Co., 531 West 5th St., Cincinnati, Ohio.

SILVER Plating Tablets, 600 brass or copper, screws, matches, etc., can be instantly plated silver in a beautiful manner with the silver plating tablets. Sample tablet, 10c. Agents wanted. Utility Co., Cardston, Alberta, Canada.

100 IMITATION Ives' Teeth, guaranteed very fine, \$2 each. H. Dodder, 2136 8th West, Seattle, Wash.

TYPEWRITER, Moving Picture machine, Redex camera. E. O. White, Malina, D.

COLUMBIA Gramophones and eight records and one week, \$30. Typewriter, two-value ribbon, book shaver, radiator, etc. \$10. Full particulars, Frank Cowles, Canton, Conn.

FATHERS, MOTHERS! Let your son learn a clean, high-class, educational trade that pays \$1,200 yearly. Mastered day or evening. Unlimited course (usually takes three to five months), \$10. Short courses also. Please call or write for particulars. EMPIRE MERGENTHAUER LINOTYPE SCHOOL, 410 First Avenue, New York City.

BAKE Guinea Pigs—Great demand, thousands used yearly, more profitable than poultry or swine. Easy to raise. I buy all you raise. Market assured. Please enclose stamp for full particulars. Edward F. Taborn, 2825 Woodland Ave., Kansas City, Mo.

Scientific Exchange Columns

UNDOUBTEDLY you have at the present time some things for which you have no further use. Do you wish to sell these things or exchange them for something for which you have immediate use? There is no surer and quicker way to do this than by advertising your articles in these columns. The **Very** people, the **Only** people, who could possibly have a use for your things read this journal. More than 20,000 interested people will see your ad. It is furthermore the cheapest advertising medium for you in the country.

The rates are: One cent per word (name and address to be counted) minimum space 2 lines. Count about 7 words to the line. **Resilience must accompany all orders.**

We reserve to ourselves the right to refuse any advertisement which we consider misleading or objectionable. Advertisements for the May issue should reach us not later than May 13th.

The Classified Columns of "The Electrical Experimenter" Bring Positive Results.

VARIABLE Battery Condenser, 21 plates and a pair of 2000 ohm phones for a good camera or other. In. 100thworth, 15 Kosciuszko St., Brooklyn, N. Y.

WANTED—2000 Ohm, double pole resistor; must be good make; will pay \$2.00. John Parsons Haller, Williamstown, Mass.

WILL SELL—Loose coupler, \$13.00; pair of Branda phones, \$5.00; lightning switch, 600 volts, \$2.50; loading coil, \$2.50; condenser Marchek variety, \$5.00; send variable condenser, \$1.00. Write for particulars, Louis Friedman, care Voshamp Bros. Company, 500 Ferry St., Philadelphia, Pa.

FOR SALE—1/2 K.W. transformer coil with vibrator, \$4.00; 4 1/2 inch Rheinstrom coil, \$3.00; E. I. Co. static machine, \$2.00; 32-caliber target revolver, 5-inch barrel, \$5.00; pair of cycle skates, \$3.00. All these articles practically new. Send stamp for list of other bargains. H. E. Davies, Jr., 5120 Main, Stratford, Conn.

EXCHANGE—Have lots of wireless and electrical dope; want printing press and outfit. Write at once. Ralph Tins, Richmond, Ind.

EXCELSION 5 H. P. tandem, 1911 single motor-cycle; fast overhauled; perfect condition; exchange for one \$100.00 wireless, or apparatus any kind. MIBER, 1005 East Division Lane, Caracas, Wash.

\$10.00 Postal or Express Money Order takes late model No. 2 L. C. Smith Typewriter. Used 100 years. Good as new. Cost \$10.00. Some bargains. MUST sell. O. H. Hamill, 2502 Jackson St., N. E., Minneapolis, Minn.

FOR EXCHANGE—Send \$5.00 field glasses; want Radioson detector. Address: Walter Pfautner, 537 2nd St., Cochranton, Pa.

FOR SALE OR TRADE—One three-slide tuning coil, one post Leyden jar, one heavy wireless key, one spark gap, one one-inch Marconi wireless coil, one Radioson detector stand, one electro wireless loading coil, one pair Branda wireless receivers, 2000 ohms. Write what you have to trade, or will sell at a bargain. Ernest E. Roebke, Lock Box 206, Universal, Ind.

FINE Antwerp to sell or exchange. Write for information. Ransford & Bruce, 20 Warrington St., Boston, Mass.

WILL swap a plate or a Film-pack camera, post-card size, for a tuning coil. Keyway Zion, St. Johns, Delaware, Wis.

FOR SALE—One loose coupled Receiving Set (two receivers), \$6.50. Rotary gap for coils and transformers, \$2.00. Electrostatic detector, \$1.00. These instruments are in excellent condition. Will exchange. I would be pleased to exchange photos of Radio Set with other amateurs. Address: Cecil Erbes, Levensville, Ill.

WILL exchange "Edison—His Life and Inventions," 2 vols. 1000 pages. "Telegraph Instruments," 4 vols. Telegraph Key and Sender. Electric Light—Pocket—Pocket Reformer, excellent condition. Value \$28.00. For 1011 Eastman Presso Junior Camera No. 1A (28444), good condition. Murr Kuttler, Cochranton, Pa.

LET me know what you want to sell or swap. Excited, 20 Warrington St., Boston, Mass.

FIELD—Marine Day and Night Glasses with 2200, 22-1/2 inch adjustment, \$30.00 value, only \$4.50. Money back if not satisfied. The Curiosity Shop, 29 S. Second St., Philadelphia, Pa.

YOUR PHOTO on a pillow top or handkerchief on high class material, Swaboda Sells; washable, will not fade. Pillow top in any one of 6 colors, namely: white, blue, green, lavender, pink or yellow. Priced to you, only \$1; 6 for \$5. Satisfaction guaranteed or money refunded. Rogers Supply Co., 4425 Washington Blvd., Chicago, Ill.

MAIL ORDER OPPORTUNITIES

EVERYTHING in the mail order line; state your wants and we will do the rest. Pacific Specialties Co., Los Angeles, Cal.

EUROPEAN War Map and chances to start a profitable business of your own, 10c. G. S. Mathews, 69 East 87th St., Portland, Ore.

FREE—A 14 Kt. Amsterdam Gem, can't tell from a genuine diamond, set in a Tiffany ring. Send 10 names and addresses from friends and 1c. to pay postage. S. E. Moller, Maplewood 3, Madison, Mass.

MAIL Order Men: Would you like to know how 21 successful mail order men do business? Especially if these men tell you their own experience in their own words. The Mail Order Business Builder gives you such information direct from these men's private offices from month to month. Send dime for sample copy of this 62-page magazine. Randolph Rose, Publisher, No. 8 Broad St., Chattanooga, Tenn.

WIRELESS

FREE—A beautiful Wireless Receiving set enabling you to receive messages 200 miles for sending only 25 boxes of my Spot Remover. Sells on sight. Be one of the first in your town to own a Wireless set. Write now, Margo Co., 702 N. 6th St., East St. Louis, Ill.

WIRELESS Amateur Attention: Improve your wireless receiving set with a Caspelle Detector, Caspelle Detector complete, \$1. Parts for Detector complete, 75c. Plans for Detector, 50c. This detector when once adjusted will never get out of order and it will last for years. The plans will show you how to make it. Anyone can make it. It is very simple. Send money order. Everett Hamm, 104 E. St., San Rafael, Cal.

50 COMMERCIAL Keys for 24. Maxwell Wireless Telegraph Co., Frohman, E. I.

"WIRELESS CHART" giving capacity, wave length, impedance, etc., values directly. Will save through condensed formulas. "Chart," prepaid, 25 cents. Send stamp for list of labor saving charts. H. Koser, Consulting Engineer, 2610 7th Ave., New York City.

AMATEURS, Exceptional Radio Apparatus. My type A time receiving set unquestionably superior to any on the market. Values up to \$500.00. Send 2c. stamp for literature. H. Y. Higgins, 30 Irving Pl., Brooklyn, N. Y.

WILL sell new Gramograph No. 2 Jester for \$5.00, prepaid. Cost \$9.00 new, used three weeks. Mark Kuttler, Cochranton, Pa.

WILL Swap—Westinghouse 7500 Alt. Circuit ammeter, zero to 200 amp. dead bent, dash pot synchronous type 9 in. across face, 5 in. deep and printing tape telegraph register, with spring motor, key roll tape, works on batteries, prints the dots and dashes. What do you offer? Write S. Webster Piper, 133 E. Antler St., Hagerstown, Md.

FOR Sale or Trade: has large stamp collection. Russell Lipes, 1224 W. 32nd St., Indianapolis, Ind.

EXCHANGE, MMEG 10 volt dynamo, worth \$4.50, perfect condition, for either: West Pocket Kodak, or V. P. Developing Tank or Static Machine. Article must be in perfect condition. Earle Chamberlain, Rowfield, Maine.

T. H. P. MOTORCYCLE Meyers, making red, books, magazines of all sorts. Will trade for wireless instruments or sell. Write to Edward Rhodes, Racine, O.

WILL exchange money order for Modern Electric, April to November, 1912, and Electrical Experimenter up to January, 1915. Walter Pranssen, Woodhall, Ill.

HAVE a Stinson "Favorite," No. 17, 22-caliber rifle. Worth \$1.00. Want a good Windmill (Electric Importing Co.) scale machine. Reuben Ellwood, Lanesboro, Minn.



Another New and Improved Tool of Millers Falls Make

Here is a new hand drill designed to do a better job in quicker time with less effort and less trouble and fulfilling each purpose perfectly.

MILLERS FALLS HAND DRILL No. 306

It is provided with a simple and effective ratchet, located on the crank handle, which is of great convenience when working in cramped corners or on a delicate job. The handle is detachable and hollowed for holding twist drills up to the largest size within the capacity of the chuck. The chuck is of the famous STAR three jaw pattern closing evenly on, and centering accurately, round shanks from 0 to 1/4 inch in diameter. Jaw springs are protected from injury.

Solid steel frame. Cut gears with a small steel working gear and steel idler gear to equalize bearings, both encased and rendered dirt-and-dust-proof. Choice hardwood stained handle, all metal parts handsomely nicked with exception of large gears.

The splendid quality of material and workmanship in this drill is typical of all tools of Millers Falls Make. Ask your dealer to show you Hand Drill 306 and also Millers Falls Bit Braces 733, Automatic Borer 3 and Rock Saw Gauge 35, new tools that include new features to make work easier.

Send for pocket catalog showing complete line.

Millers Falls Co.

DEPT. E MILLERS FALLS, MASS.

New York Electrical School

THE only school in the world devoted to teaching every angle of Electrical Industry by "actual practice." All ages from sixteen to sixty enter this school on the same level and are shown "how" and "why" in a manner that ensures absolute success.

No preparation needed to become a "learner" in this school. You can start this course any day of any week throughout the whole year.

We particularly desire to have it known that all VISITORS are heartily welcomed at this unique training institution.

Drop a postal card for free Catalogue
New York Electrical School
89 WEST 131st ST. NEW YORK

THE BEACON FOUNTAIN FLASH LIGHT

The finest example of flashlight Novelty, Convenience and Quality. Clip prevents loss, acts as a contact in use, and prevents short circuit in the pocket. Only one of the BEACON products of quality in Flashlights, Batteries, and Electrical Novelties. For sale by all good dealers.



THE "NIFTIEST" FLASH LIGHT EVER CONCEIVED

BEACON MINIATURE ELECTRIC CO.

108-110 DUANE ST., N. Y. CITY
11-17 S. DESPLAINES ST., CHICAGO



\$2500⁰⁰ a Year

Yes, that is what a full fledged Signal Engineer gets—\$2,500 a year. Many are making more than that. Even while you are learning you can hold one of the positions under a Signal Engineer paying you a handsome salary. Our profession is young. We need ambitious men and will pay you big money when you have the proper training. Send the coupon and find out about the opportunities that await you and how you can learn to become a Signal Engineer right in your own home—during your spare time.

Be a Signal Engineer

Join the ranks of a profession that is not overcrowded and in which big money is being paid. The work is fascinating. Upon your knowledge will depend the safety of thousands of lives and millions of dollars worth of freight. You are the boss,—the man who knows—and the man who gets the fat pay envelope. You can get just the kind of practical training that you need right in your own home,—during your spare time.

Send the Coupon For Big New Book

Put your name and address on the coupon or on a letter or post card and send it to us at once. We will send you the Big New Signal Book absolutely free and prepaid. Absolutely no obligations. The book and full particulars of our special offer are free. Send the coupon now.

Department of Signaling
Room 3382, Ravenswood Station
1810 Wilson Ave., Chicago, Ill.

More Men Needed

Railroads are constantly looking for competent Signal Engineers. Thousands and thousands of miles of track are now being equipped with automatic block signals. Positions paying big money are open this very minute. The men who are trained are getting the jobs. Send the coupon for the New Signal Book.

Two Big FREE

Complete Signal Engineer's Outfit and Complete Draftsman's Outfit given away absolutely free to students.

Department of
Signaling
Room 3382

1810 Wilson Ave., Chicago, Ill.

GENTLEMEN: Please send me absolutely free and prepaid your big new Signal Book. Also full particulars about your great special free outfit offer. It is distinctly understood that I assume no obligations of any kind.

Name.....

Address.....

Age.....Occupation.....



**INTIMATELY
LINKED:**

**E. I. CO.
PRICES
QUALITY
AND
SERVICE**

**SEND
FOR THIS
WONDERFUL
DETECTOR
AND**



CYCLOPEDIA-CATALOG

TO-DAY

**Electro
Importing
Company**

406 Fulton Street,
New York City.

I enclose herewith 10 cents in stamps or coin for which please send me your **Miniature Wireless Detector** and your **Electric Cyclopedic** for 1915, No. 13, 2nd edition, containing 400 illustrations and over 2000 articles and valuable information on Electricity and Wireless. Book also contains 20 free coupons for our 100 page wireless course in twenty lessons.

Name.....
Address.....
State.....

**USE THIS
COUPON**



*W. J. Delawarey
Hampton Roads Va,
7/15/14.*

*Two Importing Co,
406 Fulton St.
New York City.*

*Dear Sir: I received your
wonderful miniature detector
to-day and it is working fine
I showed it to our Radio Officer
and he gave me two dollars
for it and is using it him-
self so here is another order
for one of these wonderful detectors.
Yours respectfully,
W. J. Delawarey, JR.*